



RV-M7 GX
UHF GPS Transponder/Modem
Technical Manual

Version C12
February 2010

RV-M7 GX



RV-M7 GX with IP65 Weatherproof option



Raveon Technologies Corporation
990 Park Center Drive, Suite C
Vista, CA 92081
www.raveontech.com

Table of Contents

1.	General Information about the RV-M7	4
1.1.	Congratulations!.....	4
1.2.	NOTICE	4
1.3.	Safety / Warning Information	4
1.4.	Safety Training information:.....	4
1.5.	FCC Compliance Information.....	6
2.	Overview	7
2.1.	Features.....	7
3.	Operation	8
4.	Specifications	11
4.1.	RF And Performance Specifications	11
4.2.	General	11
4.3.	User Input and Output Signals.....	11
4.4.	GPS and Transponder Specifications	11
4.5.	Model Numbers	11
5.	Electrical Inputs and Outputs	13
5.1.	LEDs	13
5.2.	DC Power	13
5.3.	RS232/EIA232 Serial I/O Connector.....	14
5.4.	-WX weatherproof Version.....	15
	Power Cord.....	15
	RS232 serial cable for –WX version	16
6.	Configuring the RV-M7 GX	16
6.1.	Overview.....	16
6.2.	Command Mode	16
6.3.	Password Protection	17
6.4.	Setting a Parameter	17
6.5.	Reading a Parameter.....	17
6.6.	CONFIG Button	18
6.7.	Exiting the Command Mode.....	18
6.8.	Restoring Factory Defaults	19
6.9.	MODEM Commands.....	20
6.10.	GPS Additional Commands	24
6.11.	Factory –GX Default Settings	26
7.	Setup and Initial Configuration	28
7.1.	Programming Channels and Frequencies	29
7.2.	GPS Operation Mode Configuration	30
7.3.	Position Transmission.....	32
7.4.	Set the Transmission Report rate	32
7.5.	Digital Inputs (Trigger Bits)	34
7.6.	Data Transmission.....	36
	Serial Port Baud Rate	37
7.7.	Data Reception.....	37
	Serial Port Data	37
	GPS Position and Status	37
7.8.	Device Addressing.....	38
	Security Key.....	38
	ID Addressing Basics.....	39
	Time Slots.....	39
8.	Installation	40
9.	Operation	41
10.	FCC Licensing Information.....	43

11.	Technical Information	44
11.1.	Device Addressing	44
	Addressing Basics	44
	Broadcast Transmissions	45
	The Address Mask	45
	Addressing Examples:	45
11.2.	Store-and-Forward Repeating	46
11.3.	Setting the Over-The-Air Data Rate	48
11.4.	TDMA Overview	49
11.5.	Configuring TDMA Operation	50
11.6.	Debug Related Commands	50
11.7.	Tune-up and Alignment	51
	Periodic Calibration	51
	Center Frequency	52
	TX Deviation	52
	TX Modulation Balance	52
11.8.	RS232 Serial Port Options	52
	Flow Control	52
	RX Carrier Detect	53
	Busy-Channel Lock Out	53
12.	RV-M7 Diagnostic Provisions	54
12.1.	Overview of Diagnostics	54
12.2.	Reading the Diagnostic Information	54
12.3.	Status and Statistics Command	54
12.4.	ATST Command	56
12.5.	ATST1 Command (GPS Statistics)	56
12.6.	ATST2 Command	56
12.7.	ATST3 Command	57
12.8.	ATST4 Command	57
13.	Antenna Information	58
14.	Troubleshooting	59
	Symptom: Unit will not receive	59
	Symptom: Unit will not transmit	59
	Symptom: Receive light blinks, but no data is received	60
	Symptom: Long delay before transmitting	60
	Symptom: Cannot enter Command Mode	60
	Symptom: Modem appears dead	60
	Symptom: Repeater will not repeat	61
	Symptom: Transmits position, but no data	61
15.	Mechanical	62
16.	RV-M7 GX Messages	63
16.1.	\$GPTLL Target Lat-Lon	63
16.2.	\$GPGSV Satellites In View	64
16.3.	\$GPWPL Waypoint Location	64
16.4.	\$PRAVE Raveon Proprietary Message, Location-Status	65

1. General Information about the RV-M7

1.1. Congratulations!

Congratulations on your purchase of a *RV-M7* GPS tracking radio – the most advance UHF radio modem available today.

Please take a few minutes to read this manual carefully. The information presented here will allow you to derive maximum performance from your radio modem. After reading it, keep the manual handy for quick reference, in case questions arise later on.

1.2. NOTICE

Besides the fuse, there are no user-serviceable points inside this transceiver. All service work must be referred to your Authorized Service Center or Raveon Technologies Service Department.

1.3. Safety / Warning Information

WARNING - DO NOT operate theRV-M7-U radio modem when bystanders are within 2 feet (.6 meters) of the antenna.

Blasting Caps and Blasting Areas

To avoid possible interference with blasting operations, turn off this radio or remove the DC power when you are near electrical blasting caps, in a blasting area, or in areas posted: “**Turn off two-way radio.**” Obey all signs and instructions.

Potentially Explosive Atmospheres

Turn off your radio prior to entering any area with a potentially explosive atmosphere. Do not install this product for use in areas with potentially explosive atmospheres. Do not remove, install, or charge batteries in such areas. Sparks in a potentially explosive atmosphere can cause an explosion or fire resulting in bodily injury or even death.

Note: The areas with potentially explosive atmospheres referred to above include fueling areas such as below decks on boats, fuel or chemical transfer or storage facilities, areas where the air contains chemicals or particles, such as grain, dust or metal powders, and any other area where you would normally be advised to turn off your vehicle engine. Areas with potentially explosive atmospheres are often but not always posted.

1.4. Safety Training information:

Antennas used for this transmitter must not exceed an antenna gain of 0 dBd. The radio modem must be used in fixed vehicle-mount configurations or at fixed base-station sites. It is not intended for portable applications.

This radio is restricted to occupational use, work related operations only where the radio operator must have the knowledge to control the exposure conditions of its passengers and bystanders by maintaining the minimum separation distance of

following range. Failure to observe these restrictions may result in exceeding the FCC RF exposure limits.

Antenna Installation:

For rear deck trunk installation, the antenna must be located at least the following range away from rear seat passengers and bystanders in order to comply with the FCC RF exposure requirements.

For model **RV-M7-UC**:

<p>Radiated frequency and Distance RV-M7-UC (450-480MHz 5 watts) 1.97 Feet (0.6 m) FCC ID: SRS-RV-M7-UC <i>Raveon Technologies Corporation</i></p>

For model **RV-M7-VB**

<p>Radiated frequency and Distance RV-M7-VB (150-174MHz 5 watts) 90cm FCC ID: SRS-M7-VB <i>Raveon Technologies Corporation</i></p>

For model **RV-M7-VM**:

<p>Radiated frequency and Distance RV-M7-VM 152MHz 60cm FCC ID: SRS-M7-VM <i>Raveon Technologies Corporation</i></p>

For vehicular roof top installation, the antenna must be placed in the center of the roof.

1.5. FCC Compliance Information

This device complies with part 15 of the FCC Rules. Operation is subject to the following two conditions: (1) This device may not cause harmful interference, and (2) this device must accept any interference received, including interference that may cause undesired operation.

Changes or modifications not expressly approved by the party responsible for compliance could void the user's authority to operate the equipment.

NOTE: The manufacturer is not responsible for any radio or TV interference caused by unauthorized modifications to this equipment. Such modifications could void the user's authority to operate the equipment.

This product also complies with FCC Part 22, 90 and Part 95 Subpart J of the FCC rules and regulations.

The Federal Communications Commission (FCC), with its action in ET Docket 93-62, has adopted a safety standard for human exposure to Radio Frequency (RF) electromagnetic energy emitted by FCC-certified equipment. This product meets the uncontrolled environmental limits as stated in OET-65C (01-01) when operated in accordance with the operation guidelines described in this manual. Proper operation of this radio device according to the instructions in this publication will result in user exposure substantially below the FCC recommended limits.

2. Overview

The *RV-M7 GX* GPS transponder is a rugged high-speed UHF data modem with a built-in 12-channel GPS receiver. It has ½ to 5 watts of RF power output, and operates as both a GPS transponder for tracking, and a radio modem for sending and receiving data.

The *RV-M7 GX* may be configured for a number of different GPS applications, including:

- Transponder:** Periodically transmit position and status. TX only.
- RavTrack PC:** Connect the *RV-M7 GX* to a personal computer running *RavTrack PC* (or other PC software) to view a map showing location, status, log movement, set alerts, and make reports from the data.
- Radar Display:** Connect *RV-M7 GX* to a marine plotter or radar display, and icons will appear on the display showing the location of all other *RV-M7 GX* radios in the system.
- GPS display:** Connect *RV-M7 GX* to a hand-held or mobile GPS, and icons will appear on the display showing the location of all other *RV-M7 GX* radios in the system.
- TDMA Data:** GPS position reporting may be enabled or disabled, but additional data may be transmitted in the units TDMA time slot.

As well as sending position and status, the *RV-M7 GX* also has a radio modem with integrated RS232/422/485 interface.

For privacy and security, over-the air encryption is standard on every *RV-M7 GX* radio. For network versatility, the *RV-M7 GX* incorporates a 16-bit identification code, allowing up to 65,000 objects to be identified in one system. For wide-area coverage, all *RV-M7 GX* transponders may be set to store-and-forward messages from other *RV-M7 GX* transponders.

The *RV-M7 GX* is the easiest to set-up Automatic Vehicle Locations (AVL) system available, and its re-programmability makes it extremely versatile. Most parameters within the modem may be re-configured to optimize it for specialized operations, extended range, or higher data throughput.

2.1. Features

- *Transmissions include ID, position, speed, heading, voltage, temperature, input/output status, UTC time, and proximity.*
- *Ultra-fast 3mS TX-RX switching and 4-level GFSK modem allows truly "Real Time" tracking and status.*
- *Outputs and accepts NMEA 0183 GLL, TLL, WPT, GSV, and PRAVE messages.*
- *Built-in TDMA channel access allowing truly real-time tracking (200 transmission in 10 seconds)*
- *Very low current draw. As low as 25mA average.*
- *16 bit addressing for up to 65,525 different unique IDs per channel.*
- *Programmable proximity alert (1-9999 meters) and programmable position report rate (1-9999 seconds).*

3. Operation

The *RV-M7 GX* operates in a number of different “GPS Modes”, each mode specific to the application it is being used in. The mode of operation is set with one simple command, the **GPS x** command. The main GPS modes of operation are:

- 1)Transponder:** Periodically transmits position and status over the UHF radio. Its radio receiver is disabled reducing current draw. It cannot receive messages, data, or locating information from other *RV-M7 GX* transponders. 4800bps serial port.
- 2)RavTrack PC:** Connect the *RV-M7 GX* to a personal computer running RavTrack PC (or other PC software) to view a map showing location, status, log movement, set alerts, and make reports from the data. 38400bps serial port.
- 3)Radar Display:** Connect *RV-M7 GX* to a marine plotter or radar display, and icons will appear on the display showing the location of all other *RV-M7 GX* radios in the system. 38400bps serial port.
- 4)GPS display:** Connect *RV-M7 GX* to a hand-held or mobile GPS, and icons will appear on the display showing the location of all other *RV-M7 GX* radios in the system. 4800bps serial port.
- 12)Mobile Data:** Outputs WPL messages for position, and transmits and receives data. Connect the *M7 GX* to a hand-held or mobile GPS, and icons will appear on the display showing the location of all other *RV-M7 GX* radios in the system. Data sent into the RS232 port will be transmitted over-the-air in the proper time-slot, and may be received with other *M7*'s.

The different modes change the operation of the *RV-M7 GX* in a number of ways. The **GPS X** command is a “macro” that sets a host of various parameters within the *M7* to configure it to operate in the desired way. The serial-port data rate is set, the types of NMEA messages it wills send out or accept is set, as will as how the internal UHF radio is used. The table below summarizes the 4 standard GPS modes, as well as listing other specialized operation modes that the *M7 GX* supports.

GPS mode 2 is the factory default mode.

GPS Mode #	Common Usage	Serial Port Baud Rate	Output Messages	Description
GPS 0	M7 Radio Modem <i>Radio Modem. No GPS, tracking, or TDMA features.</i>	Un-changed	-	The RV-M7 GX will operate like an RV-M7 (no GPS features).
GPS 1	Transponder <i>Simple tracking, AVL, security.</i>	4800	(local GSV, GLL, RMC)	The RV-M7 GX will only transmit in this mode. The receiver is off and GPS is turned off between transmissions. This is the lowest-power consuming mode, but it is send-only.
GPS 2	PC / Base Station <i>Proprietary interface for PC applications that monitor RV-M7 Transponders.</i>	38400	\$PRAVE (local GSV, GLL, RMC)	Connect the RV-M7 GX to a PC computer running RavTrack PC (or a custom application), The PRAVE message is in NMEA format, and provides location and status information for every transponder it receives.
GPS 3	Marine Radar <i>Displaying the location of RV-M7 transponders on a ship RADAR screen.</i>	38400	\$GPTLL (local GSV, GLL, RMC)	Connect the RV-M7 GX to a marine RADAR display or plotter with a serial port, and waypoints will appear on the GPS screen at the location of all RV-M7 GX transponders within radio range. The display must support the NMEA 0183 TLL message.
GPS 4	GPS Display <i>Lowrance and Garmin GPS displays. Mobile displays.</i>	4800	\$GPWPL (local GSV, GLL, RMC)	Connect the RV-M7 GX to a mobile or hand-held GPS with a serial port, and waypoints will appear on the GPS screen at the location of all RV-M7 GX transponders within radio range.
GPS 5	-LX Receiver Only <i>Lowrance and Garmin GPS displays. Mobile displays.</i>	38400	PRAVE	Connect the RV-M7 GX to a PC computer running RavTrack PC (or a custom application), The PRAVE message is in NMEA format. No transmission capability. Internal GPS is disabled.
GPS 6	Mobile Data <i>Used to connect to 4800 baud MDT terminals.</i>	4800	\$GPWPL (local GSV, GLL, RMC)	Connect the RV-M7 GX to a mobile data terminal. Positions are received in WPL format. Serial port data capability is enabled.
GPS 7	Laser Rangefinder <i>Used to send PLTIT rangefinder messages with data.</i>	4800	\$PLTIT (local GSV, GLL, RMC)	Connect the RV-M7 GX to a laser range finder such as the TruePulse360 to transmit target information.
GPS 8	Personal Locator <i>Mode used for Personal Locator applications.</i>	38400	\$PRAVE (local GSV, GLL, RMC)	Portable personal location use. Man-down feature enabled. Do not connect to any I/O pins except 2,3 and 5.
GPS 9	TDMA Diagnostics <i>Displaying TDMA slot diagnostic information</i>	38400	\$PRAVE (local GSV, GLL, RMC)	Factory use only. Used for timing analysis.
GPS 11	NMEA GPS and Data <i>Output local GPS NMEA data plus send/receive data like a modem.</i>	38400	(local RMC)	Unit operates as a standard M7 radio modem with no TDMA support, except it also outputs RMC data from the internal GPS receiver every 30 seconds.
GPS 12	TDMA Data <i>Unit does not send position, but will send data using TDMA slot assignments.</i>	38400	\$PRAVE (local GSV, GLL, RMC)	Used to transmit serial port data over the air in the correct TDMA time slots. WMX protocol on serial port. PRAVE position receptions. Unit does not transmit its position out over the air.
GPS 13	GLL & VTG tracker <i>Unit sends position. Output format is GLL & VTG, so sending ID is not present. Use to track one thing.</i>	4800	GLL & VTG of remote device, not the local.	Used to track one object. Every time it receives a position report from a remote device, it outputs the GLL and VTG sentences with the data from the remote device.

When the **GPS x** command is executed, it configures the following parameters, so if your application requires any of these to be non-standard, you must issue the command to modify them AFTER the **GPS x** command is issued.

- *Serial port output message format*
- *Echo characters (ATEX command)*
- *NMEAOUT*
- *NMEARATE*
- *Hardware flow control*
- *Serial port baud rate*
- *Data mute setting*
- *WMX protocol*

4. Specifications

4.1. RF And Performance Specifications

Please consult the individual specification sheet for the RF and performance specifications of your specific M7 GX transponder.

4.2. General

All measurements made per TIA-603-B. Certain bands are for export only. Consult the specification sheet for you specific Raveon product for regulatory approval information.

Frequency:	Model RV-M7-VA	136-155MHz
	Model RV-M7-VB	150-174MHz
	Model RV-M7-UC	450 – 480MHz
	Model RV-M7-UB	419 – 440MHz
	Model RV-M7-UA	403 – 434MHz

4.3. User Input and Output Signals

Serial port baud rates	1200, 2400, 4800, 9600, 19200, 38400, 57600, 115200
Voltage levels	RS-232, RS-422, and RS-485 complaint levels
Modem handshake signals	RTS, CTS, DTR, DSR, CD
Transceiver RF	50 ohm BNC (TNC on –WX version)
GPS Connection	SMA 50 ohm, 3.3V for amplified antenna
Power	B+ input and Ground
Digital Inputs	3 standard, 2 on –WX version
Standard Power Connector	Phoenix 18 36 18 9 (Raveon P/N 1J165-3)

4.4. GPS and Transponder Specifications

Number of channels	12
Horizontal accuracy (24 hour static)	<2.5m 50%, <5m 90%
Acquisition (-130dBm, 50%)	<40sec cold start, <8sec hot start
Sensitivity	Tracking -150dBm, Acquisition -142dBm
NMEA Output sentences	WPL, TLL, GLL, GSV, PRAVE
Position report rate, programmable	1 to 9999 seconds
Position report resolution	0.0001 degrees
Voltage report resolution/accuracy	0.1V/10%
Temperature resolution and accuracy (enclosure temperature)	2 degrees C/4 degrees C
Number of digital inputs	3
Velocity resolution and accuracy	1km / 1km per hour
GPS connector	SMA
Active GPS antenna voltage (RV-M7 GX output voltage on SMA)	3.3V, 20mA maximum

4.5. Model Numbers

The model number of the *RV-M7* modem identifies its operating frequency band, rf power level, and bandwidth. The models are:

RV-M7-*ab-c-oo* where:

a = The band (V=136-174MHz, U=406-512MHz)

b = Sub band (A,B,C,...)

c = Channel Spacing (blank=12.5kHz, W=25kHz)

oo = Options (-GX for GPS, -WX for waterproof enclosure)

Other frequency bands, power levels, and channel spacing are available. Contact the factory for your specific needs.

Sub-Bands

Sub-Band Letter	VHF (RV-M7-V...)	UHF (RV-M7-U...)
A	132-150MHz	403-434MHz
B	150-174MHz	419-440MHz
C		450-480MHz

5. Electrical Inputs and Outputs

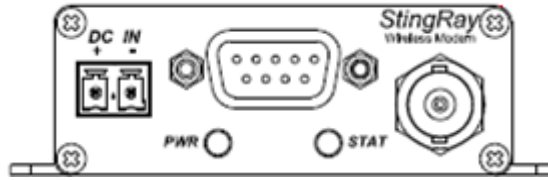

The front panel of the *RV-M7 GX* modem has these features:

1. RF connector
2. Power LED
3. Status LED (Receive data = green, TX = red)
4. 9-Pin Serial I/O connector
5. DC Power Jack

5.1. LEDs

The status LED visually show the current status of the radio.

Status LED (TX) This LED blinks red when the transmitter keys and is putting out RF power. It blinks green upon the reception of data or RF carrier.

Power LED (PWR) This LED does a short blink, once every two seconds, indicating to the user that the power to the modem is ON and the modem is working. When the modem is in the command mode, this LED will blink on and off, once per second.

When the GPS is trying to acquire satellite lock, the Status and Power LEDs will **alternately blink** back and forth. This usually takes 10-20 seconds upon power-up or loss of GPS satellite signal.

5.2. DC Power

DC power for the modem is connected to the 2-pin DC power input jack labeled DC IN. Use the supplied cable to connect the DC power. The **red wire is positive (+)** and the **black wire is negative (-)**. Its connection is optional, as the user may alternately apply power to Pin 9 and ground to pin 5 of the 9-pin I/O connector. If the power cable run is over 3 feet long, Raveon recommends at least 18 AWG wire be used.

The *RV-M7* modem is supplied with a 6-foot DC power cable, Raveon part number 1C738-1.

Note: The *RV-M7* has in internal 3-amp mini-fuse (automotive type) to protect it and its power source against reverse voltage and serious hardware failures. In the event it is blown due to a reverse voltage, it may be replaced by removing the internal circuit board and replacing the fuse. This must be done by a qualified electronic technician using ESD precautions.

5.3. RS232/EIA232 Serial I/O Connector

The RS232 9-pin serial I/O connector is a female 9-pin D-subminiature connector having the following pins configuration. It is pinned out so that it may be plugged directly into a computer or PC's 9-pin COM port.

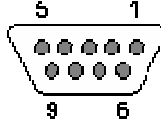

Front-view of DB-9 connector on modem (female)

Pin	Name	Dir	Function	Level / Specification
1	CD	out	Carrier detect	If enabled, indicates presence of carrier. Logical 0 (+ voltage on RS-232) means carrier is present. If disabled, it is asserted (0) whenever the modem is operational, and not in the configuration mode. It will be a 1 when the modem is in the configuration mode.
2	RxD	out	Receive data	Data out of the modem.
3	TxD	in	Transmit data or IN2	Data into the modem. Also used as digital input IN2 for exception reporting. GND or floating for a 0, >3V for digital 1. If enabled for digital inputs, the serial data entering this pin is ignored (except in the command mode). Use the TRIGBITS command to set which bits are used as inputs.
4	DTR	in	Data terminal ready or IN0	Normally ignored by the <i>RV-M7</i> modem. May control the power-state of the modem in low-power mode if this feature is enabled. Also used as digital input IN0 for exception reporting. GND or floating for a 0, >3V for digital 1. Use the TRIGBITS command to set which bits are used as inputs.
5	GND		Ground connection	Signal and power ground
6	DSR	out	Data Set Ready	Normally is set to 0 when modem is powered on and running. Modem sets to a 1 when in low-power mode.
7	RTS	in	Request to send or IN1	Used to stop/start the flow of data coming out of the modem TxD pin. 0 = OK to send, 1 = don't send. Leave disconnected if not used. Also used as digital input IN1 for exception reporting. GND or floating for a 0, >3V for digital 1. Use the TRIGBITS command to set which bits are used as inputs.
8	CTS	out	Clear to send	Used to stop the flow of data going into the RxD pin from the device connected to the <i>RV-M7</i> . 0 = OK to send, 1 = don't send. If the <i>RV-M7</i> cannot accept more data, it will negate this signal (set to a 1).
9	Power	In/out	DC power (not ring signal)	User may supply the DC power to the modem on this pin.

Note: RS-232 signals use positive and negative voltages to represent digital 1s and 0s. A positive voltage is a 0, and a negative voltage is a digital 1.

This pin-out allows it to be directly plugged into a computer's 9-pin serial port using a conventional 9-pin RS-232 serial cable. To connect it to a modem, or peripheral that has a serial port, you will need a "null-modem" cable. See Appendix A for more information on wiring a null-modem cable.

5.4. -WX weatherproof Version

The -WX version of the product is functionally the same as the standard version, except it is IP65 rated for weather resistance. It has special water-resistant connectors on it, and a sealed enclosure to keep moisture out of the unit.

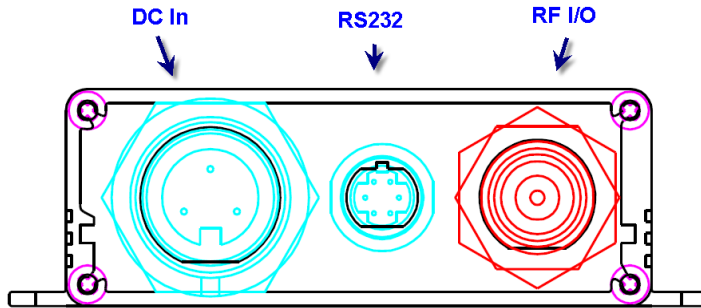

The DC Input connector is a Bulgin PX0412/03P

The RS232 I/O connector is a Hirose HR30-6R-6P(71)

The RF I/O connection is a TNC female.

Power Cord

The DC power cord uses a Bulgin connector, part number SA3349/1. Please note, diagram 2 is only for use with WX-Z models.

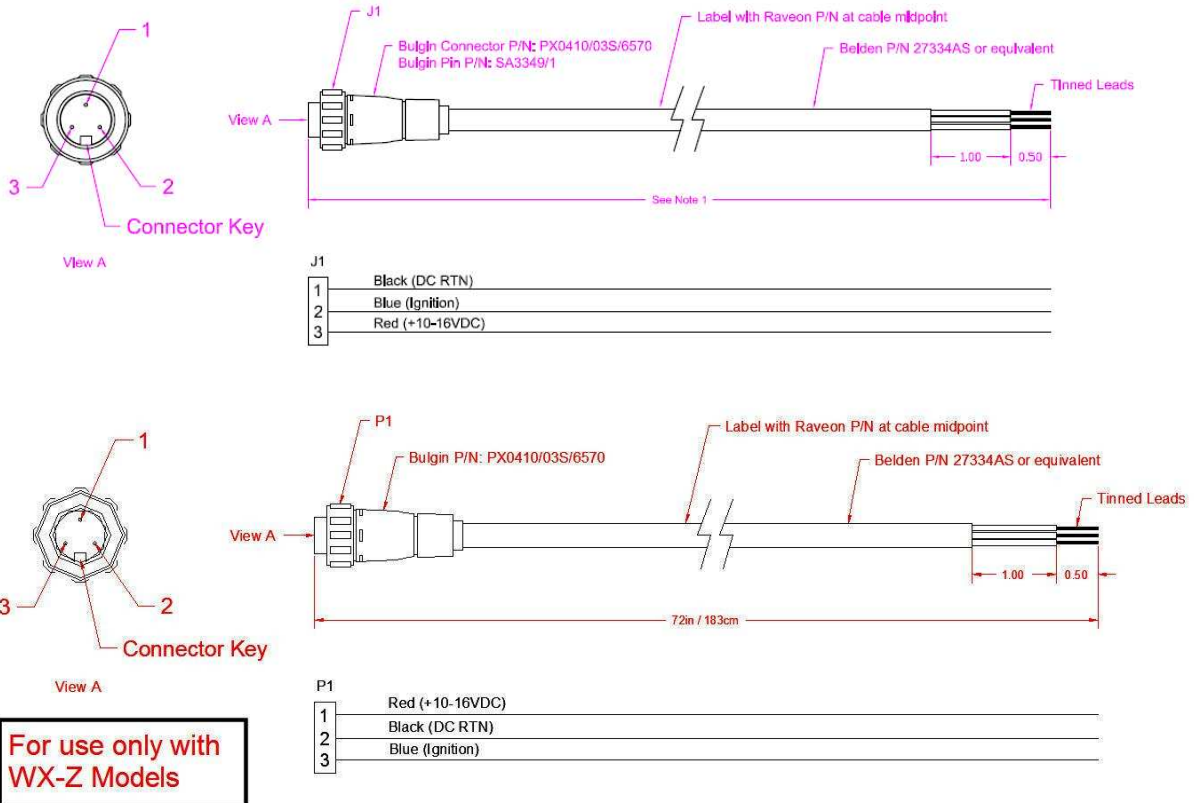

RS232 serial cable for –WX version

The RS232 serial cable uses at Hirose connector, part number HR30-6P-6S(71).

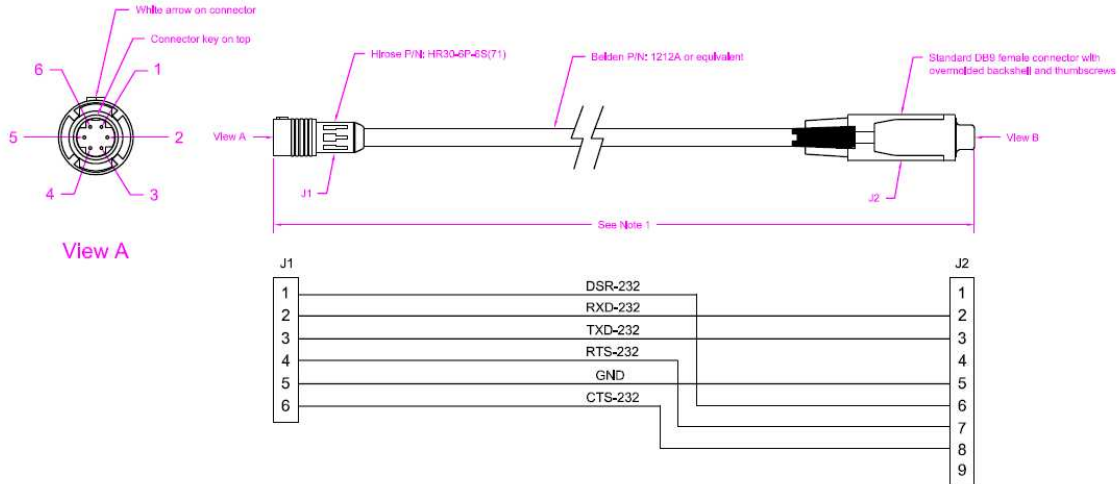

6. Configuring the RV-M7 GX

6.1. Overview

The RS232 serial port on the unit is used to send and receive data over the air, as well as to configure the RF modem. In normal operation, the user sends serial data into the TxD pin of the user port, and this data is transmitted over the air. Received data from another RF modem is output to the user via the RxD pin of the user port. This is the default operating condition of the RF modem. No special characters, hardware control lines, or timing is required to operate the *RV-M7* modem.

If the *RV-M7 GX* is used as a GPS transponder (**GPS 1** mode), the serial port need not be connected to anything. The internal GPS will initiate the transmissions of position and status.

There is also a “Command Mode” used to program and configure the *RV-M7 GX*. In the Command Mode, the *RV-M7 GX* modem accepts commands via the serial port TxD pin. The commands can be used to change certain internal parameters of the *RV-M7 GX* modem as well as to read-out the current configuration and diagnostic statistics.

6.2. Command Mode

The *RV-M7 GX* modem may be put into a “Command Mode”, by entering a sequence of three plus characters (+++). To keep the *RV-M7* modem from unintentionally entering the Command Mode because of the +++ pattern occurring in a stream of data entering the modem, there must be a pause in the data stream

before the +++ as well as a pause after the +++ is sent. If either pause is missing, the modem will not enter the command mode.

Using serial communications software such as *HyperTerminal*, send the 3-character command sequence “+++”.

When the *RV-M7 GX* modem first enters the Command Mode, it sends the phrase “RV-M7” out its serial port, and then an “OK” sequence. The “OK” sequence is a sequence of 4 characters:

“O”, “K”, <CR>, and <LF> characters (<CR> = ASCII 0D, <LF> = ASCII 0A)

6.3. Password Protection

One M7 series products with firmware version C0 or higher, the user interface may be password protected. If it is password protected, the radio will output a “password:” prompt when entering the command mode.

When in the command mode, to enable the use of a password enter:

Password xxxx <CR>

Where xxxx is the 2-7 digit password you would like to protect the user interface with.

To disable password protection, enter:

Password 0 <CR>

Note: If the user-interface is password protected, and the Config button on the M7 is pressed, for security reasons, the encryption phrase is automatically erased.

6.4. Setting a Parameter

To set a parameter in the *RV-M7 GX* modem, enter the Command Mode as described above. Then enter the proper command, a space, the parameter, and then a carriage return. For Example, to set the destination address of the *RV-M7 GX* modem to 1234, enter the following command:

ATDT 1234 <CR>.

M7 series radios automatically save changed parameters to non-volatile EEPROM memory whenever the parameter is changed.

6.5. Reading a Parameter

To read the value of a particular setting, issue the command with no parameter. The modem will return the value followed by an “OK”.

For example, if the user enters the command to read the *RV-M7*’s destination address and its address was 1234, the user would issue the following command:

ATDT<cr>

and the modem will respond with:

1234 <CR> <LF>

OK <CR> <LF>

To get on-line help with a command, enter the command and put a question mark for the parameter. For example, to see what the ATDT command is used for, type **ATDT ?**. The modem will respond by listing a brief description of the command. To see a list of all commands, type **HELP**.

6.6. CONFIG Button

If certain parameters within the *RV-M7 GX* transponder are modified in a manner that erroneously causes the modem to cease functioning or if the user cannot enter the command mode via the “+++” method described above, there is a small push-button internal to the *RV-M7* to assist in this situation. This “CONFIG” button may be pressed at any time, and forces the *RV-M7 GX* into a known operational state. The CONFIG button is located inside the *RV-M7 GX*. Remove the rear cover, exposing the circuit board. The button is in the center of the circuit board as shown below.

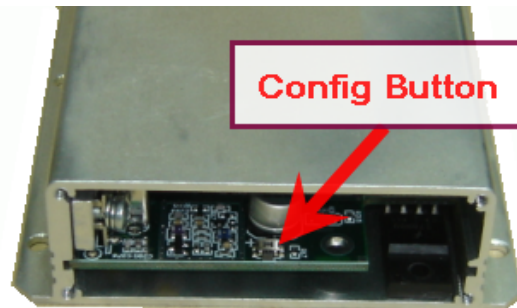

The default settings that the *RV-M7 GX* will revert to when the CONFIG button is pressed are:

1. *Serial port 9600 baud, 8 data bits 1 stop, no parity*
2. *Serial port flow control is off.*
3. *ATCT setting set to 60000 (60 second time-out)*
4. *Encryption KEYPHRASE is erased (if it was set to some KEYPHRASE and the user-interface had password protection enabled)*

Even though the serial baud rate reverts to 9600 baud when the CONFIG button is pressed and the IO port is RS232, it will revert back to the settings programmed into the *RV-M7 GX* once the Command Mode is exited.

Important Note! If the user-interface is password protected, AND the *Config button* on the M7 is pressed, for security reasons, the encryption phrase is automatically erased.

6.7. Exiting the Command Mode

There are three ways to exit the command mode. They are:

1. **ATCN** Issuing the **ATCN**. The M7 radio will exit the command mode, and begin normal operation.
2. **EXIT** Issuing the EXIT command. The M7 radio will exit the command mode, and begin normal operation.

3. **Time Out.** After a pre-set amount of time (60 seconds is the factory default time), the modem will automatically exit the Command Mode, and continue normal operation. Changes will not automatically be saved. This time-out duration may be set with the **ATCT** command.

6.8. Restoring Factory Defaults

The **AT&F** command may be used to restore the modem back to the factory-default condition. The table in Section 6.9 lists all of the radio modem related commands. Use this command with caution, as it will erase all previously configured parameters. It will cause the modem to revert back to the factory-defaults, as shown in the command table, “Factory Default” column. The only parameters that it does not restore to default are the radio calibration values R0-R9, and RA.

The **GPS&F** command resets only the GPS related settings back to factory defaults. The modem itself keeps its settings. The GPS commands that are reset are shown in Section 6.10.

6.9. MODEM Commands

Command	Command Description	Parameters	Factory Default
ATAK	Enable/Disable ARQ – When ARQ is enabled, this modem will automatically send an ACK packet back to a modem that sends it data. 0=off, 1=on.	Range: 0 – 1	0 (no ACKs sent)
ATAT	Silence AFTER Sequence - Sets period of silence after the command sequence characters in mS.	Range:0 – 1000 (mS)	500
ATBD	Baud Rate – Sets serial com port baud rate (bps). Over-the-air (throughput) baud rate is set with ATR2 command. If a PC's serial baud rate is set higher than the fixed over-the-air baud rate of the module, hardware handshaking may be required.	Range: 0 – 7 0 = 1200 5= 38400 1 = 2400 6=57600 2 = 4800 7=115200 3 = 9600 4 = 19200	5
ATBC	Busy Channel Lock Out – Enable/disable the BCL. If enabled, the modem will not transmit on a radio channel that is busy (has RF on if). 0-OFF, 1=ON.	Range: 0-1	0
ATBT	Silence BEFORE Sequence – Sets period of silence before the command sequence character in mS.	Range: 0-1000 mS	500
BW	Set/Read IF Bandwidth - Sets the IF bandwidth to narrow (N) or wide (W). Narrow is for 12.5kHz channels, and wide is for 25 or 30kHz spaced channels. This command is only used on the VHF version of the product. The UHF does not support w	N	N or W
ATCH	Configure Hardware Flow Control – Enable (1) or disable (0) flow control. When enabled, the modem will monitor the RTS line, and if it is negated, stop sending data out the serial port. If disabled, the modem will ignore the state of RTS, and always send out characters.	1 = Enable 0 = Disable	0
ATCD	Carrier Detect Threshold – Read/set the carrier detect threshold, in dBm. -113 means -113dBm. Version firmware and higher.	-113	-120 to -60
ATCN	Exit AT Command Mode – Exits module from AT Command Mode and returns it to normal operation mode.	none	none
ATCT	Command Time Out – If no valid commands have been received via the serial port within this time period (in milliseconds), modem returns to normal operation mode from Command mode. If the CONFIG button inside the RV-M7 is pressed, this parameter will be automatically set to 60000.	Range: 100-60000mS	60000
ATDT	Destination Address to call – Sets address of the modem to send data to. Note, in the RV-M7 GX this parameter is entered in decimal format. Each digit may be a 0,1,2,3,4,5,6,7,8, or 9. Do not use A,B,C,D,E, or an F.	Range: 0-9999	0001
ATE	Echo – Character echo set on (E1) or off (E0). This applies to the Command Mode only.	Range: 0 , 1	1 (echo)
ATF	Display frequencies – Display all of the frequencies programmed into all of the channel memories.		N/A
ATFT	Transmit Frequency – Program the transmit frequency for this channel. Enter in Hz or in MHz. The frequency will	Range: See product data sheet. For MURS products,	See product

	automatically be saved in non-volatile memory (flash) for this current channel number.	frequency cannot be changed.	data sheet.
ATFR	Receive Frequency – Program the receive frequency for this channel. Enter in Hz or MHz. The frequency will automatically be saved in non-volatile memory (flash) for this current channel number.	Range: See product data sheet. For MURS products, frequency cannot be changed.	See product data sheet.
ATFX	TX and RX Frequency – Program the receive and transmit frequency for this channel. Enter in Hz or MHz. Same as issuing an ATFR and an ATFT command. User cannot change frequency in the MURS version of the product. Use ATHP to change channels in the MURS version.	Range: See product data sheet.	N/A
ATGP	Group Number – Set or read the unit's Group Number. 0 means this feature is not used. If GP is set to any number other than 0, then all radios communicating with this unit must have the same group number programmed into them.	Range 0-255	0
ATHP	Channel Number – Select separate channels to minimize interference between multiple sets of modules operating in the same vicinity.	Range: 1 - 6	1
ATHS	Show History – Show a table of listing the most recent receptions, and the IDs that the data was sent from	No parameter	
ATIO	Configure the I/O The proper hardware option must be installed in the modem. All RV-M7 modems support RS-232 mode. –GX version use IO mode 5. Do not change this.	Range: 0 - 5 0=RS232 1=Ethernet 2=RS485 dup 3=RS485 simplex 4=RS422 5=GPS	0
ATIC	Read Current Draw Read the current draw in mA. Accuracy is within 20% of actual current draw.	Range: 0-9999	N/A
ATJF	Read/set the CTS threshold – Set the serial buffer threshold where the CTS line is negated. By default the ATJF level is at 80% of the internal buffer size.	1 - 2000	3800
ATL	Enable/Disable the LEDs – 1 = LEDs always off. This reduces some power consumption. 0 = LED operate normally.	0 or 1	0
ATMK	Address Mask – Configures local and global receive address space. Each digit may be a 0,1,2,3,4,5,6,7,8,9,A,B,C,D,E,or F. In most applications, this is kept at F000. Set to 0000 to ensure the unit receives data from ALL other radios, regardless of the TOID in the transmission.	Range: 0000 - FFFF	F000
ATMY	Unit Address – Configures the individual; address for this unit. Each digit may be a 0,1,2,3,4,5,6,7,8,9,A,B,C,D,E,or F. Note: FF is interpreted as a group. See addressing section.	Range: 0000 - FFFF	0001
ATNB	Parity – Selects parity format. Settings 0-4 transfer 8-bits over antenna port and generate the parity bit on the RF receiving side.	Range: 0 – 5 0 = none 1 = Odd 2 = Even 3 = Mark (1) 4 = Space (0)	0
ATND	Number of Data Bits – Set/read the number of data bits.	Range: 5 - 8	8
ATNS	Stop Bits – Selects the number of stop bits.	Range: 1-2	1
ATPE	Packet Error Display – Shows statistics to compute packet-error rate. Displays Packets Per Minute (PPM) and a running total.	None (display PER) 1 = reset counters 2 = Stop PER display	None
ATPO	RF Power Output . Set or show the RF power output setting. Value is in percent, from 0% to 100%. Use and RF wattmeter to confirm the power setting, and adjust the % accordingly to obtain the desired RF power level. For the MURS version, the ATPO setting is limited to 40%.	0-110	100

ATRO	Symbol Peak Deviation – Set the peak FM deviation of the transmit symbols. Note: This can be a negative number to invert the modulation.	Range: -1000 – 1000	120**
ATR1	Select CD pin output signal – CD may be RF carrier detect, or modem data detect.	Range : 0 - 2 2 = Always assert CD 1 = Data CD 0 = RF CD	1
ATR2	Over-The-Air bit rate - This is the data rate the radio uses to send data over the air. All RF modems in the network must use the same over-the-air baud rate. Refer to section 11 for information on how to set the OTA baud rate.	Range: 0 = 800 5 = 9600 2L 1 = 1200 6 = 19200 4L 2 = 2400 7 = 5142 2L 3 = 4800 8 = 9600 4L 4 = 8000 4L 9 = 2000 2L 10=14.4k 4L	3
ATR3	Serial Port time out – Number of mS of no activity on the serial port before transmitting the data in its buffer.	Range: 1 - 5000	20 (mS)
ATR5	Preamble length – The number of bytes to send over-the-air in the pre-amble.	Range: 3 - 255	4** (Varies based on data rate and radio type. 7 typical)
ATR8	Frequency Offset. Used to set the radio on the center of the radio channel.	Range: -500 to +500	0**
ATRB	Number of retries. If this modem does not get an ACK back when it sends data, this is the number of times it will re-transmit the packet and wait for an ACK. 0=disabled feature.	Range: 0-99	0 (ACKs are not used)
ATRF	RF Carrier Required – When enabled, there must be RF energy on the channel for the modem to output data. Streaming data mode only. 1=RF required. 0=ignore RF energy when receiving.	Range: 0, 1	0 (no RF required)
ATRQ	Receiver Signal Level – Reads the Receiver Signal strength this instant, and returns the level in dBm.	Range: -40 to -130 (dBm)	-
ATRS	RSSI (Receive Signal Strength Indicator) – Returns the signal level of last received packet. The reading is in dBm. Usable for relative comparison of signals, but absolute value is within 10dB at -90dBm.	No parameters. Returns a number : -50 to -140 (dBm) varies by model.	none
ATRV	Disable Remote Access – When enabled (set to a 0), the modem will respond to over-the-air RPR requests, Pings, and over-the-air commands. Default is OFF (1).	0= Remote Access on 1=Remote Access off	1
ATSL	Serial Number – Reads and returns a unique serial number for this unit.	Read Only 1 - 999999999	unique
ATSH	Show – Display the configuration of the modem. This will return a page of ASCII characters, showing the main configuration parameters.	none	None
ATSM	Sleep Mode Operation Enable – When set to 1, the DTR input line controls the RV-M7's low-power operation. When set to 0, the RV-M7 will not go into LPM, regardless of the state of the DTR pin. When set to 2, the modem is forced into a low-power mode, disabling the receiver and transmitter. When set to 4, the receiver is off, but the transmitter will still transmit GPS positions and data.	Range: 0, 1, 2, 3, 4	0
ATST	Statistics – Show the unit's operational statistics. See Statistics section of user manual.	0, 1, 2, 3, 4, or 5	None

ATTD	Transmit Test Data – When issued, the modem will begin transmitting data. The type of data sent is set in the parameter. Entering a <CR> will terminate the transmission.	0 = Go back to normal 1 = Random 3 = 1010... at ¼ baud rate 4 = TX all 0s 5 = TX all 1s 6 = Test Points ON 7 = Transmit CW 8 = Transmit 1010101...	
ATTE	Read product temperature – Read the internal temperature of the unit's circuit board in degrees Celsius.	-40 to +99	-
ATTT	Max Packet Size – Set the maximum number of bytes in an over-the-air packet.	1 - 512	500
ATVB	Read DC input Voltage – Returns the DC input voltage reading, in mV (12500 = 12.5VDC input).	None	none
ATVR	Firmware Version – Returns firmware version currently loaded on the module.	Read Only, 3 characters	none
ATXn	Show or Configure the Repeat Table – Set the addresses that this unit will store-and-forward data to/from. n = 1, 2, 3, or 4 designating the entry in the table to show or edit..	<i>Four parameters</i> aaaa bbbb cccc dddd where aaaa=Source Address bbbb = S.A. Mask cccc = Destination Address dddd = D.A. Mask	
ATXR	Enable/Disable Store and Forward Repeating – 0=disabled, 1 – enabled.	0 or 1	0 (Off)
ATHX	Enable/Disable single-hop repeating – 0=any number of repeats, 1 – unit will not repeat a packet that was already repeated.	0 or 1	0 (multi-hop OK)
ATXT	Read/set repeater delay – Read or set the repeater delay in mS. This is the time between receiving a data packet, and the time the repeater will re-send it.		0
AT&F	Restore Factory – Restore the factory default values. This command will not erase the calibration values. After this command executes, the modem will still be in the CONFIG mode.		none
CONFIG	Show Configuration. Display the settings of every parameter in the unit. If the parameter is 1, then the help text is not displayed, If the parameter is 2, the configuration is output in strictly the format used to program another unit.	None, 1, 2	-
BAND	Show/display the radio band. Displays the frequency band that the radio is configured for, along with the upper and lower frequency, in MHz.. BB is the band code, ll is the lower frequency in MHz, and uu is the upper frequency in MHz.	None	BB, ll, uu
MODEL	Read Model number. Read the model number.	None	-
REPEAT	Turn Repeater feature on/off. If 1, a quick way to enable repeating all packets. If 0, disables the repeat feature.	0 (off) or 1 (on)	0
RPR	Remote Procedure Request. Used to request execution of a command on a remote mode (over the air). See <i>RV-M7 System Protocol</i> manual for information on using this feature.		
SHOW	Show/display an overview of the radio's configuration.	None	-

** indicates values that are calibrated in the factory and are unit-specific. If the "Radio Type" is changed, these will need to be re-calibrated.

6.10. GPS Related Commands

The following commands are unique to the –GX version of the *RV-M7*. When you execute any of these commands, the new parameter is automatically stored in EEPROM.

Command	Command Description	Parameters	Factory Default
ATHX	Single-hop repeat. Only applicable if repeater function is enabled. (ATXR = 1) 0 = repeater will repeat as programmed. 1 = will not repeat any packet that has already been repeated.	0 or 1	0
ATMC	Set/Read Channel Access Method. 0=Carrier-sense CSMA. 1=Time-Division Multiplex, where user-data is transmitted in the unit's TDMA slot.	0 or 1	0
DATAMUTE	Set/Read Serial Port TX Data Mute. 0=Unit will transmit serial data over the air. 1=Unit will not send any serial port input data over the air, only position transmissions. Works in TDMA mode only	0 or 1	0
FREEWHEEL	Freewheel time. Read/set the number of seconds that the unit will continue to transmit when it does not have GPS lock.	1-7200	120
GPS	GPS Operation Mode. Set the GX version's Operating mode.	1 – 9	2
GPS&F	Reset all GPS (-GX version) parameters. Set the GX version's Operating mode to GPS mode 4, and sets all GPS parameters to factory defaults. It does not erase frequency or other radio-related parameters.	-	-
IDLERATE	IDLE TX Interval. Set the number of seconds between position transmissions when the unit is idle (has not moved more than TRIGDX meters).	0-9999 seconds	10
KEYPHRASE	Privacy Security Key Code. Set the privacy key for this device. It must be the same key as used on all other Raveon products in your system. It secures radio transmissions from unauthorized reception. Set it to 0 to disable security encryption of data.	2-16 ASCII characters.	"RAVEON"
MAXBYTES	Read Max num of Bytes. This command asks the modem for the maximum number of bytes it can transmit in one TDMA slot. It is read-only.	-	N/A
NMEAOUT	Enable/Disable NMEA messages. Configures the M7 GX to output standard NMEA messages (GGA, GLL, RMC) out its serial port. NMEAOUT 0 disables the messages. NMEAOUT 1 enables them.	0, 1	1
NMEAMASK	Set/Read NMEA message bit mask. The NMEAMASK register contains configuration bits to enable various NMEA standard messages from the internal GPS receiver that will be sent out the serial port. The parameter is the decimal integer value of the mask.	0-9999	258 (RMC, GLL, GAA)
NMEARATE	Set/Read NMEA message rate. Set/read the number of seconds between NMEA messages from the internal local GPS.	1-99	5
OUTPUT	Set Output format. Set/read the serial port output format to output GPS position/status messages. This parameter is set by the GPS x command. It may be manually reconfigured AFTER the GPS x command is issued. 0=none, 1=\$PRAVE, 2= \$GPTLL, 3=\$GPWPL, 5=PIN, 6=\$QVPOS, 9=Debug, 11=\$GPGGA, 12=\$GPRMC, 12=GGA, 13=GLL, 14=GLL&VTG		\$PRAVE Set by GPS mode command.
PREFIX	ID Prefix. Set an ID prefix. The prefix is 1-8 characters that will be put in front of the ID when reporting an ID as	1-8 ASCII characters	V

	a waypoint name. A dash means no prefix. Default is a capitol letter V.	Set it to "0" for no prefix.	
PROX	Proximity Alert. Set a minimum proximity distance. When any <i>RV-M7 GX</i> with properly configured ID codes and KEYPHRASE comes within this many meters of this unit, a proximity warning is triggered. The report interval will be at the TXRATE setting, and report the proximity warning at least 8 times or until the distance between the two <i>RV-M7 GXs</i> increases beyond the PROX distance.	0-9999 0=feature disabled	Disabled (0)
REPEAT	Enable -GX Repeating. This simple command enables the repeater feature of the <i>RV-M7 GX</i> , and configures it for standard operation. The user may alternately use the ATX and ATRX commands, but they are more complicated to use. This command enables the unit to repeat all messages it receives, as long as the first digit of the 4-digit ID matches its first digit. (It repeats IDs 0001 thru 0999).	0 off 1 configure repeater.	0
REPORT x y	Set duration of Location/Status Reporting. This is a static command (not stored in EEPROM). This command sets how many seconds a unit should report for. Report 0 disables GPS reporting altogether. REPORT 1 re-enables normal operation. Report 1 xx enables the unit to report for xx seconds.	X: 0, 0 Y: 1-99999	1
SLOTQTY	Quantity of TDMA Slots. Normally this parameter is set to 1. Each unit gets one slot. To facilitate data transmission, it is possible to set this to a number other than 1. For example, if set to 3, and the ID of the unit is 0008, the unit will be allowed to transmit in slots 8, 9, and 10.	1-9999	1
SLOTNUM	Change the TDMA slot number. Use this command with caution! This will change the TDMA slot assignment, leaving the ID (MYID) unchanged. Typically, the ID and the slot number are the same. Once this command is used, the TDMA slot number for this transceiver will no change if the ID of the device is changed. Set SLOTNUM to -1 to force the Slot Number to be automatically set to the MYID of the radio. This is the factory default setting.	-1, 1-9999 (Decimal number, not hex)	N.A. By default the Slot Number is auto-set to the MYID
SLOTTIME	TDMA Slot duration. Configure the width of a TDMA slot. 50mS increments.	50 - 1000	200
TALKERID	Set/read the talker ID. The TALKERID is the two-digit prefix for the \$xxTLL message.	xx	GP
TDMATIME	Set/read TDMA Frame time. The length of one TDMA time frame, in seconds.	0-3599	10
TDMADATA	Set/read TDMA Data Priority. Configure the unit to give transmit priority to serial port data over GPS position data. 0=GPS position priority, 1=Serial Data priority. If set to 1, GPS position transmissions are suppressed when there is serial port data to send. If set to 0, GPS is always sent, and extra space in TDMA slot will be filled with any available serial-port data.	0, 1	0 (GPS Position is priority over data)
TRIGBITS	I/O Change Reporting. Sets/reads which bits are used as "transmission triggers". This is a HEX number. Bit 0 is IN0, bit 1 is IN1.... IN2 is the serial data input, so if the unit is used to send data, do not set TRIGBITS to a number greater than 3. Note: all input bit status is always sent each transmission, regardless of this setting.	0-7	0
TRIGPOL	Polarity of the input bits. 0 = normal active high operation(causes unit to transmit when it goes high), 1 = Inverted, active low. This is a HEX number. Bit 0 is IN0,	0-FF	0 Active high

	bit 1 is IN1....		
TRIGEX	Report on change. Sets which input bits cause a report on change. If a particular bit is a 1, then it will trigger a report when it changes. The input bit must also be enable with the TRIGBITS. This is a HEX number. Bit 0 is IN0, bit 1 is IN1...	0-FF	0
TRIGDX	Distance trigger. Set a distance (in meters) threshold beyond-which the unit will transmit its position and status. If set to 0, the unit always reports at the TXRATE. If set to an distance greater than zero, then the unit reports at the TXRATE intervals if it has moved this distance since the last report. If it has not moved, it will still report its position, but at the rate set by IDLERATE. If IDLERATE is set t 0, then the unit will not report its position when not moving.	0-999	0
TRIGSPEED	Speeding Report. Set a speed (in kilometers/hour) threshold above-which the unit will begin reporting its position and status. Set to 0 to disable this feature.	0-999	0
TXRATE	GPS Report Rate. Set number of seconds between GPS reports. This is also the rate at which the internal GPS will measure position, speed, etc. Even if the unit is not moving, the GPS periodically measures position and speed to determine if it has triggered a speed or position transmission. Set to TXRATE and IDLERATE both to 0 to totally disable position reporting.	0 - 9999	10
TLLPARAM	\$GPTLL Message parameters. This command sets flags that tell the <i>RV-M7 GX</i> which internal parameters to append to the target "Name" when it outputs the TLL message. Bit 0 = temperature, Bit 1= velocity, Bit 2=RSSI, Bit 3 = voltage. Enter the number in decimal: 10 sets bits 3 and 1, 8 sets bit 3, 9 sets bits 3 and 0	0-15	0

6.11. Factory –GX Default Settings

For the UHF *RV-M7 GX* model, the factory defaults GPS settings are:

Radio channel 1	464.500 MHz (RV-M7-UC)
Radio channel 1	151.625 MHz (RV-M7-VB)
Radio channel 1	151.820 MHz (RV-M7-VM)
GPS Mode	4 (Use with GPS display)
Serial port output message:	\$GPWPL
Over-the-air baud rate:.....	4800 baud, 2-level
Serial port.....	RS-232, 4800baud, N/8/1
Hardware flow control	Off
RF Power Output	5 watts
Channel number selected	1
Position/Status report interval	10 seconds
Minimum movement distance to report	0 (reports even when idle)
Transmission trigger inputs	0 (digital inputs disabled)
Security KEY	RAVEON
Proximity Alert	0, off.
I/O Change reporting.....	0, off
ID Prefix	V

Slot Quantity 1

7. Setup and Initial Configuration

1. Connect a DC power source to the DC IN connection on the front of the modem.
2. Connect a good quality antenna, cut to the operating frequency, to the RF connector on the front of the modem. Use a good quality antenna, and place it as high-above obstructions as possible.
3. Connect a computer terminal, or PC computer running *HyperTerminal*, to the 9-pin I/O connector. The factory default serial ports settings are 4800 bps, 8 data bits, 1 stop, no parity. Note, the serial port may be 38400bps if the RV-M7 GX is in GPS modes 2 or 3.
4. Put the *RV-M7 GX* into the command mode. (enter **+++** per Section 6.2)
5. Program the modem's operating frequency to your desired operating frequency. This is done with the **ATFX xxx.xxxxx** command. See the Section 6 for information describing the various parameters that may be modified in the modem. In most applications, the default settings from the factory will work fine.

Note: The MURS version of the M7 (RV-M7-VM), the unit is pre-set to the 5 MURS channels on channels 1-5. The user cannot change the frequency of the M7, only the channel number.

6. With the unit in the command mode, change any of the default operating parameters that must be modified. From the factory, the modems are configured and delivered ready-to-use. Out of the box, they will communicate on the default radio channel using the factory defaults. [Raveon highly recommends you test them first with the factory defaults and see how they work before reprogramming them.](#) In general, the parameters you may want to modify will be:

ATFX	Frequency for this channel. Set to your frequency.
GPS x	Set the operating mode of this unit. See Section 7.2 for a list of the various modes.
ATMY	The individual ID of this unit. Default is 0001. Number all of your <i>RV-M7 GX</i> transponders with a different MYID. Raveon recommends sequentially numbering them, starting at number 1.
ATDT	The address of the unit this modem will talk to. Default is 0001.
ATMK	The network address mask. Default is F000. This means this unit will receive all transmissions from any other unit with an ID beginning with 0 (0001 thru 0999).
KEYPHRASE	Enter a security key code. Use any word or phrase 1-16 characters long. It is case-sensitive. DO NOT FORGET WHAT YOU SET IT TO! The KEYPHRASE is the only parameter that cannot be read out of the <i>RV-M7 GX</i> . It must be the same as the KEYPHRASE programmed into all the other <i>RV-M7 GX</i> transponders in your system. The factory default KEYPHRASE is RAVEON , call capitals.

SLOTNUM This will change the TDMA slot assignment, leaving the ID (MYID) unchanged. Typically, the ID and the slot number are the same. Once this command is used, the TDMA slot number for this transceiver will not change if the ID of the device is changed. Set SLOTNUM to -1 to force the Slot Number to be automatically set to the MYID of the radio. This is the factory default setting.

7. Connect your serial data device (GPS, Plotter, PC...) to the 9-pin connector on the front of the modem.

The radio is now ready to use. Any serial data going into the modem will be transmitted over the air, and any data received over the air will be sent out the serial port.

Remember, that from the factory, all *RV-M7 GX* modems are configured to simply work. Plug in power and connect to the serial port at 4800 baud, and the modems will communicate on the default channel. Change the channel frequency to your specific frequency, and they will be ready to work on your channel.

What you will see come out of the serial port with the factory default settings (GPS 4 mode), is a *\$GPWPL...* message, every time one *RV-M7 GX* in your system transmits.

7.1. Programming Channels and Frequencies

The *RV-M7* modem has memory for up to 6 channels. In most applications, only one channel is needed. A channel is a pair of frequencies, one for transmit and one for receive. They may be different or they may be the same. You may program any valid frequency into any channel number. To program a channel, perform the following steps.

1. Change to the channel you wish to program, using the **ATHP x** command, where x is the channel number. The factory default is channel 1.
2. Program the frequency for this channel x, using the **ATFX** command. Note that the frequency may be entered in MHz as long as you use a decimal point. For Example, enter **ATFX 450.1** to set the channel frequency to 450.100MHz. Alternately, you may enter the frequency in hertz by entering **ATFX 450100000**. You must enter all of the zeros if you enter the frequency in hertz. To enter different TX and RX frequencies use the **ATFR** and **ATFT** commands.
3. Review the frequency setting with the **ATFT**, **ATFR**, or **ATFX** command. To see a list of all of the channels, enter **ATF**.
4. To change the radio channel, use the **ATHP x** command while the modem is in the command mode.

The *RV-M7-VM MURS* version of the M7 has five user selectable channels. The channel is selected with the **ATHP** command. The *RV-M7-VM* modem is factory-set to these five channels, and the modem cannot be programmed to operate on any frequency other than these five.

- | | |
|---|-------------|
| 1 | 151.820 MHz |
| 2 | 151.880 MHz |

- 3 151.940 MHz
- 4 154.570 MHz
- 5 154.600 MHz

7.2. GPS Operation Mode Configuration

The **GPS x** command is provided to make configuring the RV-M7 simple to setup for common configurations. The following table summarizes the various standard configurations. Choose the configuration that is most similar to your usage, and execute the appropriate **GPS x** command.

See **Section 3** for a complete list of the various GPS modes.

To review the overall configuration of the GPS features of the RV-M7 GX radio, type GX when in the command mode. A listing of the GPS features will be displayed. An example listing of a *RV-M7 GX* in GPS mode 2 is shown below:

```
-GX GPS mode      : 2   RavTrack PC
Serial Protocol   : Raveon $PRAVE
Serial port baud rate: 38400 N 1
Position TX Interval : 60seconds (will TX when still.)
Proximity Alert   : OFF
External Triggers : OFF
Speed limit trigger : 0 (OFF)
TX method         : 1 (Time Slot)
mS per TDMA slot  : 200   4 X 50mS ticks
TDMA slot number  : 4
TDMA frame time   : 2
Waypoint Prefix   : V
Security key is enabled.
OK
```

After the **GPS x** command is executed, the operation of the unit may be customized for special applications. The following table summarizes the parameters that may be modified, *AFTER* the **GPS x** command.

RV-M7 GX GPS Modes of Operation

The **GPX x** command is used to configure the RV-M7 GX for various common configurations. The following table lists the parameters that are configured and saved when the GPS x command is executed. After the command is executed, individual parameters may be modified to customize the operation of the unit.

Parameter	GPS mode	Output Message Format	NMEA Position	Local GPS NMEA messages	Position/status report rate	Data communication via RS232 also	Capable of Speed triggered position reports	Speed Trigger default	Minimum Distance Trigger	Digital Input Triggers	Serial Port Baud Rate	Can be a repeater	Minimum
Command used to modify this parameter	GPS x	Position message format OUTPUT x	Local NMEA data NMEAOUT x	Local NMEA messages NMEAMASK	TXRATE xx	DATAMUTE x		TRIGSPEED xx	TRIGDX xx	TRIGBITS xx	ATBD X	Repeat X Default = 0(off)	
Transponder	1	Nothing (X=3)	No (0)	GGA, GLL, RMC	10	TX only (1)	Yes	0 (off)	0 (off)	0 (off)	4800	NO	
RavTrack PC	2	\$PRAVE (x=1)	Yes (1)	GGA, GLL, RMC	10	TX & RX (0)	Yes	0 (off)	0 (off)	0 (off)	38400	Yes	
Radar	3	\$GPTLL (x=2)	Yes (1)	GGA, GLL, RMC	10	TX & RX (0)	Yes	0 (off)	0 (off)	0 (off)	38400	Yes	
GPS Display	4	\$GPWPL (x=3)	No (0)	GGA, GLL, RMC	10	RX only (1)	Yes	0 (off)	0 (off)	0 (off)	4800	Yes	
-LX receive only	5	\$PRAVE (x=1)	No(0)		10	RX (1)	No	N/A *1	N/A	N/A	38400	Yes	
GPS display and/or MDT	6	\$GPWPL (x=3)	No(0)	GGA, GLL, RMC	10	RX & TX (0)	Yes	0	0 (off)	0 (off)	4800	Yes	
Data Modem with GPS info	11	nothing (x=3)	Yes(1)	RMC	10	RX & TX (0)	No	N/A	N/A	N/A	38400	Yes	
Data Modem with GPS info	13	\$GPGLL & GPVTD	No(0)		10	RX & TX (0)	Yes	0 (off)	0 (off)	0 (off)	4800	Yes	C10

Notes: *1. -LX units typically do not have a GPS receiver in them. They receive position reports over the air from other units, but do not transmit position or status.

7.3. Position Transmission

When the RV-M7 GX transmits its position, it also reports other status information such as voltage, input bits, temperature, velocity, and heading. All of these parameters are compressed into a short data packet, and sent over the air in the proper TDMA time slot. Each *RV-M7 GX* is assigned a time slot, based upon its ID. ID 1 is slot 1, ID 2 is slot 2...

Position/status reporting happens in one of 2 intervals.

A) At the **TXRATE** setting. This is the transmit frequency interval setting. The user configures **TXRATE** to be shortest acceptable interval between reports. The factory default is 10 seconds.

B) At the **IDLERATE** setting. This is the idle reporting interval, usually the longest acceptable time between position reports.

IDLERATE is used as a slow-reporting rate for parked vehicles, vehicles that have no active trigger inputs, no proximity alerts, and that the user has programmed them to require a minimum movement distance before they will report.

7.4. Set the Transmission Report rate

Using the **TXRATE xx** command to set the report rate, in seconds, for the *RV-M7 GX* transponder. For example, if you wish the *RV-M7* to report every 5 minutes, set the report rate to 300 seconds (**TXRATE 300**).

If you only want the *RV-M7 GX* to report position and status when it is moving, set the **TXRATE xx** to the desired time between position transmissions. Then, program the **IDLERATE xx** to the desired number of seconds between reports when the unit is not moving (idle).

Important!: Set the minimum distance the unit must move before a transmission occurs with the **TRIGDX xx** command. If **TRIGDX** is set to zero, then the unit will always report at the interval set with the **TXRATE xx** command.

For example, to transmit every 2 minutes when idle, and every 10 seconds when moving more than 500 meters, use these commands:

IDLERATE 120 (to set the idle moving update interval to 2 minutes.)

TRIGDX 500 (tells it to report at the **IDLERATE** if it does not move this far)

TXRATE 10 (configures it to report every 10 seconds whenever it is moves more than **TRIGDX** meters)

The following diagram illustrates the logic behind the various programmable parameters that can be used to configure the *RV-M7 GX* to trigger position transmission. The logic inside of the *RV-M7 GX* shown is tested at a user-programmable rate, called the **TXRATE**. The **TXRATE** is the time interval between *RV-M7 GX* position/status radio transmissions.

Set to **TXRATE** and **IDLERATE** both to 0 to totally disable position reporting.

The diagram clearly shows that if **TRIGDX** is set to 0, the unit will always transmit when it is supposed to, at the interval programmed into the **TXRATE**.

RV-M7 GX Transmission Trigger Diagram

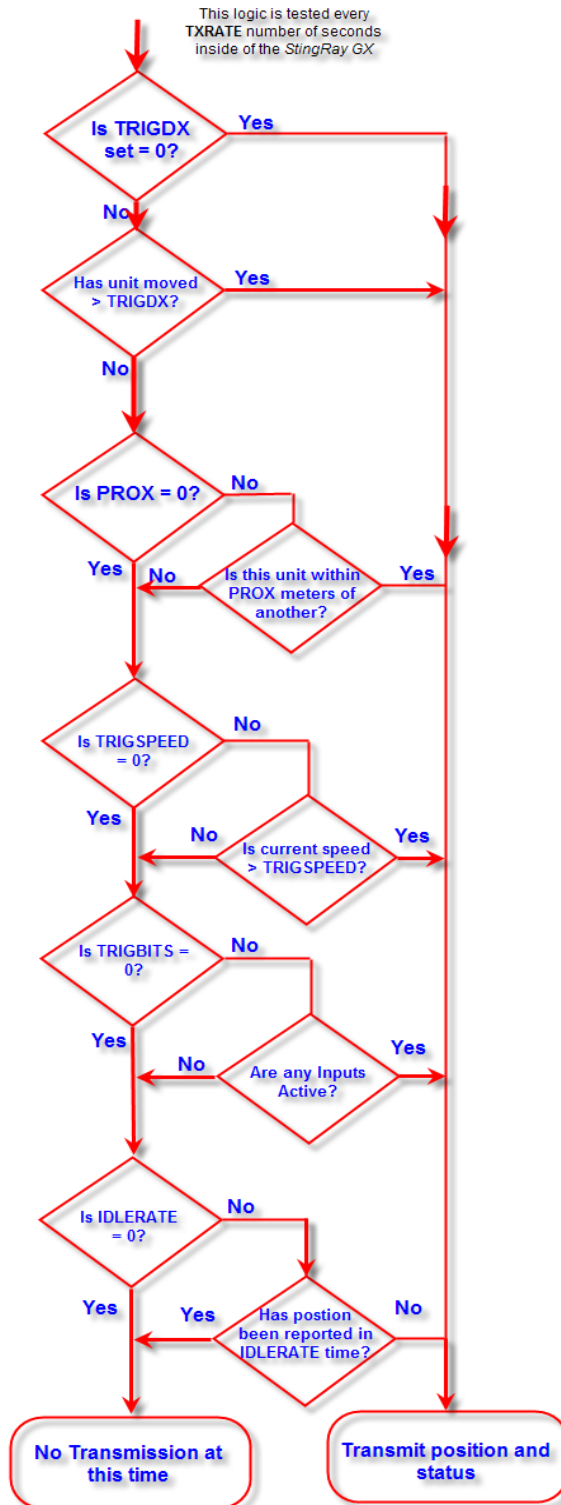

7.5. Digital Inputs (Trigger Bits)

The stock *RV-M7 GX* Transponder has 3 digital inputs. The status of these input bits is transmitted every time the M7 reports its position.

When configuring an M7 GX, you may configure any or all of the digital inputs to be “*Trigger Bits*”. The status of all bits is transmitted every time, but when a bit is designated as a *Trigger Bit*, it will also cause the M7 to wake-up if it is sleeping, and triggers it to send a transmission as soon as it can. They are called Trigger Bits because the bits can be used to trigger the M7 to transmit at the faster TXRATE instead of the slower IDLERATE.

The M7 GX has low-power modes and an idle transmission rate (IDLERATE). The M7 GX may be configured to use bits designated as *Trigger Bits* to come out of low-power mode or transmit at a faster rate. But, regardless of the rate or Trigger Bit designation, the status of the digital input bits will be transmitted along with each position report. Beginning with firmware version C2 (March 2010), if a bit is designated as a Trigger Bit, its state will be latched when it triggers, and the latched state is transmitted. Older version of firmware do not latch the state, and thus the My reports the state of the bit at the moment the position is transmitted. C2 and higher report the latched state of the trigger bit.

Bits that are designated *Trigger Bits* are digital inputs that trigger the *RV-M7 GX* to trigger a report of the M7’s position and status. Normally these inputs are used for RS-232 signals, but they may be used for general-purpose digital inputs. The *RV-M7 GX* may be configured to trigger a position/status report based upon the digital input bits state.

Important: If the digital input function is not needed, the **TRIGBITS** setting must be set to **0**. This is the factory-default setting, and unexpected transmission may happen if the digital inputs are enabled and not used.

If you are not using digital inputs, **TRIGBITS** must be set to 0. (**TRIGBITS 0** command)

If the *RV-M7 GX* was configured to transmit less-often when it is not moving (**IDLERATE** command), activation of the digital inputs will override this causing the unit to report at the interval programmed with the **TXRATE** command.

The digital inputs may be configured to trigger active high, active low, or active on a change in state. The following table lists the available digital inputs on the standard *RV-M7 GX*:

RS-232 Pin	Function
4 - DTR	Input 0
7 - RTS	Input 1
3 - TXD	Input 2
5 - Ground	GND

There are 3 commands that must be configured to use the digital inputs:

- TRIGBITS x** This command enables or disables individual bits for use as input triggers. If a bit is designated a Trigger Bit, then its state is latched until it is transmitted.
- TRIGPOL x** Sets the polarity of the input trigger bit. 0=active high, 1=inverted, active low. Setting TRIGPOL 0 will mean all trigger bits are active high, and their state will be latched as a high (1) if the bit ever goes high.
- TRIGEX x** Sets which bits are used to report on exception. Exception reporting is when a position/status report is generated when an input changes either low-to-high or high-to-low. A Trigger Bit that is set to trigger by exception with the TRIGEX command will report 0 if it does not change, or 1 if it changed since the last time the M7 reported position.

The xx parameter is the hex binary representation of the bits. Refer to the following table to see the value for x.

<i>IN 2 (TXD)</i>	<i>IN 1 (RTS)</i>	<i>IN 0 (DTR)</i>	<i>Hexadecimal Representation</i>
0	0	0	0
0	0	1	1
0	1	0	2
0	1	1	3
1	0	0	4
1	0	1	5
1	1	0	6
1	1	1	7

For example, to enable bits 0 and 2 (DTR and TxD pins) to be used as digital input, issue the following command:

TRIGBITS 5

If the bits are to be normally active high, then the polarity must be set to 0 (**TRIGPOL 0** command). To set bit 0 so that it is inverted (active low), use the following command:

TRIGPOL 1

This will cause the unit to transmit when bit 0 (DTR pin) is low.

To enable exception reporting, that is transmit when a pin changes from low-to-high or high-to-low, use the **TRIGEX** command. When **TRIGEX is 0**, all inputs are active either high or low. When a bit is set to 1 in **TRIGEX**, then that bit will cause the unit to transmit position/status anytime it changes state. The M7 will report the bit as a 1 if it changes state, or 0 if it did not change state.

For example, to configure the unit to transmit position when bit 0 changes state, issue these commands:

TRIGBITS 1 (enables bit 0)

TRIGEX 1 (configures bit 0 for exception reporting)

To configure all bits to be used to report when they change, issue these commands:

TRIGBITS 7 (enables bit 0, 1 and 2)

TRIGEX 7 (configures bit 0, 1, and 2 for exception reporting)

To configure bit 0 to be used to report when it changes, bit 1 to cause a report when it goes low, and disable bit 2, use these commands.

TRIGBITS 3 (enables bit 0 and 1, disable 2)

TRIGEX 1 (configures bit 0 for exception reporting)

TRIGPOL 2 (configures bit 1 for active-low reporting)

When a digital input triggers a transmission, the transmission will not occur immediately. It will occur when the M7 GX is supposed to report in at the rate programmed into its **TXRATE** parameter. For example, if the **TXRATE** is set to 2 seconds, the unit will transmit every 2 seconds when an input is triggered. If an input is not triggered, the unit will not transmit its position/status (as long as no other event such as speeding or proximity triggered a transmission).

When no inputs are triggering a transmission and no other events are causing the unit to want to transmit, the RV-M7 GX will report in at its **IDLERATE** period. For example if **TXRATE** is **2** and **IDLERATE** is **300**, then the unit will report in every 2 seconds when an input trigger occurs, but will only report in every 5 minutes when input triggers are not happening.

Important: If **TRIGDX** is **0**, the RV-M7 GX will always report at the TXRATE setting. The digital inputs will be ignored, although their status is always sent over the air. **TRIGDX** is the minimum distance the RV-M7 GX must move to trigger a transmission. When 0, it always must report. Set **TRIGDX** to some number of meters to ensure the digital inputs are checked.

7.6. Data Transmission

To transmit data, send one or more bytes of data into the serial port of the modem. When a full packet of data has been collected into the internal buffer of the modem, or when there is a pause in the data, the modem will automatically key its transmitter, and send the data over the air.

GPS mode 1 and GPS mode 4 do not support data transmission. GPS mode 1 does receive serial-port data not because it is a transmit-only mode. It will transmit, but it will not receive data over the air. GPS mode 4 will receive data and it will transmit position and status, but it will not transmit serial data entered into the serial port. Serial port transmit data is disabled because GPS mode 4 is normally used to connect the a hand-held or mobile GPS display to the RV-M7. The RV-M7 will send \$GPWPL messages to the GPS to display the location of other StinRay

GX radios. The GPS will normally output various NMEA messages from its serial port. These NMEA messages from the external GPS must not be transmitted, or the radio channel will become much too busy. The *RV-M7 GX* “mutes” its data input when configured in GPS mode 4.

The *RV-M7 GX* will send position/status as well as transmit and receive serial data when it is in GPS mode 2.

Serial Port Baud Rate

While the modem is transmitting, the user may continue to send more data into the *RV-M7*. Because the buffers in the *RV-M7* are full-duplex, the serial port data rate and the over-the-air data rates are independent. The serial port baud-rates may be set slow to accommodate legacy equipment, or set at high-speed to minimize latency. The over-the-air data rate is usually 4800 baud for narrow-band channels, and 9600 baud for wide-band, although faster or slower rates may be used.

7.7. Data Reception

Serial Port Data

When the *RV-M7 GX* receives RS232 data over the radio, it checks it for errors, and if it is error-free, it will send it out the serial port. Again, the serial port may be set to any baud rate the user wishes, and the radio receiver and transmitter will continue to operate independently of the baud rate.

When the modem receives a radio signal, it will assert the CD hardware signal on the RS-232 serial port if it was configured to do so.

GPS Position and Status

When the *RV-M7 GX* receives a position report and status from another *RV-M7 GX*, it will send this information out its RS232 port, formatted as configured with the **OUTPUT x** command. See Section 6.10 for detailed information on the type and format of message output from the *RV-M7 GX* when a position/status report is received from some other unit. Note, the **GPS x** command is a macro that sets many parameters, one of which is the **OUTPUT**. When the **GPS x** command is executed, it will set the **OUTPUT** setting to the appropriate message format for the particular GPS mode. After the **GPS x** command is executed, you may then issue the **OUTPUT x** command to modify the output protocol.

The position/status messages that the *RV-M7 GX* is able to send out of its serial port are:

- | | |
|---------|---|
| None | No position message output. Output 0 disable the device from outputting any message when a position report is received. |
| \$PRAVE | Raveon Position & Status. Output 1 This message is sent out of the <i>RV-M7 GX</i> when it is operating in the GPS 2 mode. This message is used by third-party and PC applications for tracking location and status information. |
| \$GPTLL | NMEA Target Lat Long. Output 2 This message is commonly sent by marine RADAR receivers to notify plotting devices of the location of a RADAR target. |

The *RV-M7 GX* can output this message when it receives a position report from other *RV-M7 GX* transponders. A plotter or display connected to it that supports the TLL message, should put an icon on its screen at the location specified by the *RV-M7*. The icon name is the MYID of the *RV-M7* that transmitted its position over the air.

- \$GPWPL** ***NMEA WayPoint List. Output 3*** This message is commonly used to share waypoint locations among GPS units. The *RV-M7 GX* can output this message when it receives a position report from other *RV-M7 GX* transponders. A GPS connected to it, should put a waypoint on its screen, and in its database, at the location specified by the *RV-M7*.
- \$QVPOS** ***QVPOS message format. Output 6*** Used when the system requires this QVPOS format..
- \$PMGNWPL** ***Proprietary WLP message format. Output 7*** Used when the system requires this Magellan format.
- \$GPRMC** ***NMEA GPS Position Fix Data. Output 11*** This message looks like local NMEA data, but is actually the position information from the remote device. It has no ID field, so it is useful for tracking only one device
- \$GPGGA** ***NMEA GPS Position Fix Data. Output 12*** This message looks like local NMEA data, but is actually the position information from the remote device. It has no ID field, so it is useful for tracking only one device
- \$GPGGA & VTG** ***NMEA GPS Position Fix Data. Output 14*** This message looks like local NMEA data, but is actually the position information from the remote device. It has no ID field, so it is useful for tracking only one device.

7.8. *Device Addressing*

Security Key

The security KEY programmed into every *RV-M7 GX* transponder ensures that only *RV-M7 GX* transponders with the exact same security code can receive position and status information. The security key is case sensitive, so “**Raveon**” and “**RAVEON**” are two different keys.

The security code may be from 2 to 16 characters long. The longer the code, the more secure it is and the less likely anyone could guess what it is. It is up to the user to select and set this code. If the *RV-M7 GX* is not used in a system where security and privacy are a concern, then it is OK to leave the factory-set code.

If it is important that the *RV-M7 GX* transmissions and system be secure, Raveon suggest you program the KEY to be a random sequence of letters and numbers at least 8 digits long.

When you program your own security code into your *RV-M7 GX* transponders, write it down in a secure place. This parameter cannot be read out of the *RV-M7 GX*. If you forget what it is set to, you will have to reset all the security codes in all of your *RV-M7 GX* Transponders.

Use the KEYPHRASE command to set the key phrase. For example, to set the key phrase to Jkl53hhp type:

KEYPHRASE Jkl53hnp <enter>

ID Addressing Basics

ID addressing is used to differentiate one RV-M7 Transponder from another. Each must have a unique number programmed into them, so that when a position report is received, the *RV-M7 GX* that sent the message can be identified. This is called the MYID of the unit that sent the message.

Each *RV-M7 GX* has a MYID programmed into it, and is represented as a 4 digit decimal number. *RV-M7 GX* IDs may be any number between 0001 and 9999. The Unit Address is programmed with the **MYID xxxx** command, and the ID of the destination modem it sends its messages to (the Destination Address) is configured with the **ATDT xxxx** command.

The factory default **MYID** in all *RV-M7 GX* modem is 0001, and 0001 is also the default for the Destination ID also. The ID of your particular *RV-M7 GX* may have been configured by your dealer or distributor. If so, it is labeled on the rear of the unit. If it is not labeled with an ID, the factory default ID is in it.

The default Address Mask is F000, which means the *RV-M7 GX* will receive a transmission from any other RV-M7 as long as the first digit matches, in this case, is a 0.

Make sure you set the **MYID** of each *RV-M7 GX* in your system to a different number.

For example, to set the ID of your *RV-M7 GX* to 17, enter:

MYID 17 <enter>

To set your RV-M7 to send its position and status data to RV-M7 number 1, enter:

ATDT 1 <enter>

To set your address mask to receive all messages from units with IDs 1-999, and exclude 1000-9999, enter

ATMK F000 <enter>

Time Slots

The *RV-M7 GX* uses a transmission scheme popular in mobile-telephones called TDMA (Time Division Multiple Access). Each *RV-M7 GX* is allocated a time-slot to use for sending and receiving radio messages.

Refer to Section 11.3 for detailed explanation of the TDMA scheme. The important point to understand is that for optimum efficiency in a *RV-M7 GX* system, begin sequentially numbering the MYID of the *RV-M7 GX* transponders at ID 0001. The second RV-M7 should be ID 0002, and so on.

The *RV-M7 GX* transponders have internal clocks with 20 ticks-per-second. They can measure time and initiate transmissions 20 times every second (every 50mS). The TDMA time slot is configured to be some number of these ticks. The factory default allocation is 4-ticks for one time-slot. So each TDMA time slot is 200mS long, and thus in 10 seconds, up to 50 *RV-M7 GX* transponders may report

position. These parameters are programmable, and may be re-configured based upon the type of system they are used in.

7.9. Local NMEA data from the internal GPS

The M7 GPS transponders and the Atlas PL personal locators may be configured to output NMEA 0183 GPS messages from its internal GPS receiver. For GPS tracking, these GPS transponders can receive GPS position reports from other radios, and they may also be configured to output their own GPS location via their serial port.

Following is a list of the NMEA messages that are available (as of revision C2 of the Firmware).

NMEA Message	Bit Number (zero based)	Bit Mask (hex format / decimal)
GGA	0	0x001 / 1
GLL	1	0x002 / 2
RMC	9	0x100 / 256

Once you set the “GPS Mode” of the radio using the GPS X command, you can change the NMEAMASK parameter to modify with of the NMEA sentences will come out the serial port.

For example, to have only the RMC sentence come out the serial port, use the following command”

NMEAMASK 256

To have the GGA and GLL come out the serial port use this command:

NMEAMASK 3

The NMEAMASK parameter is the sum of all of the decimal values of the individual bits corresponding to the NMEA messages.

8. Installation

1. Secure the *RV-M7* modem using the mounting holes on the side flanges of the unit.
2. Connect a DC power source to the DC IN connection on the front of the modem. Use the supplied cable, or 18AWG wire, and connect the RED wire to +, and the black wire to – (ground). The black wire and the case of the *RV-M7* should be connected to earth ground.

3. Connect a good quality antenna, tuned to the operating frequency, to the RF connector on the front of the modem. Use a good antenna, and place it as high-above obstructions as possible.
4. A separation distance of at least 20 centimeters must be maintained between the transmitter's radiating structures and the body of the user or nearby persons.
5. Connect a GPS antenna to the SMA connector of the *RV-M7 GX*. Although a passive antenna may work if the cable length is very short, it is recommended that an amplified antenna be used, rated at 3.3V operation.
6. Connect the computer, terminal, controller, or other hardware device that will be using the *RV-M7* modem to its DB-9 serial I/O connector using a shielded cable. Secure it to the *RV-M7* with the two mounting screws on the sides of the DB-9 connector.
7. If the antenna is mounted outdoors, use a lightning arrestor in-line with the antenna, and properly ground the antenna and the *RV-M7* chassis to an earth ground.
8. Connect Digital Inputs. The stock *RV-M7 GX* has up to 3 digital inputs, using the input pins of the RS-232 serial port. An open circuit or ground is a 0, and if they are connected to a positive voltage greater than 3V, they are a digital 1.

RS-232 Pin	Function	
4 - DTR	Input 0	
7 - RTS	Input 1	
3 - TXD	Input 2	
5 - Ground	GND	Connect to vehicle chassis or other ground point.

9. Operation

Once power is applied to the *RV-M7 GX*, the internal GPS will begin to try to lock onto the GPS satellites.

The two LEDs on the front of the *RV-M7* will begin to alternately blink red back-and-forth at a 1-second rate. (1/2 second one is red, 1/2 second the other is red) This indicates the internal GPS receiver is trying to lock onto the GPS signals.

After 10 to 60 seconds, depending upon the satellite strength, the red alternating blinking will stop. This indicates the internal GPS receiver is locked onto GPS satellite signals, and has a position fix.

The *RV-M7 GX* will only transmit if it has GPS lock. If the GPS antenna is broken or obscured, the unit will not report position or status.

When it is locked to GPS, it will transmit its position and status at the interval programmed into the **TXRATE** parameter.

In GPS mode 1 (Transponder), the unit will power-down the radio receiver because it does not receive any over-the-air messages. It will also power-down the GPS if the **TXRATE** setting is long enough for it to turn the GPS off, and back-on before the next time it needs to report position. For example, if the TXRATE is set to 120 (2 minutes), the RV-M7 GX will power the GPS off for most all of this time, only turning on the GPS long enough before it needs to transmit so that it can get a position fix. In GPS modes 2-4, the radio receiver is always on. GPS mode 1 is the lowest power-consumption mode.

10. FCC Licensing Information

RV-M7 radio modems operate on radio frequencies that are regulated by the Federal Communications Commission (FCC). In order to transmit on these frequencies, you are required to have a license issued by the FCC.

Almost everyone engaged in public safety activities - as well as private organizations, are required, to obtain a radio station license from the Federal Communications Commission if they wish to use a radio transmitter.

The FCC will help you through the licensing process. Raveon will also be glad to assist in this process, and help you obtain your license. It is quite easy.

You can find the basic information you need to begin the process at the FCC website. If you are engaged in public safety activities, you can go directly to:

<http://wireless.fcc.gov/publicsafety>

If you are a business, commercial, or institutional organization, you can go directly to:

<http://wireless.fcc.gov/services/ind&bus>

In either case, you will be shown the regulations and the information you will need to gather before you get started - your desired operating frequencies, wideband/narrowband, antenna type and size, power/wattage, etc. You'll also get information on how to obtain the necessary application forms - either in hard-copy or electronic format - and how to proceed.

The FCC website also offers a list of Frequency Coordinators. These are private organizations officially certified by the FCC to help you through the process, and who in most cases will handle the actual filing of your application. With few exceptions, you must apply for an FCC license through a Frequency Coordinator. They are located throughout the country, making it easy for you to find one that is familiar with radio operations in your area.

There are companies who specialize in assisting with licensing radio modems. You may consider contacting one of the following:

Atlas License Company and Data Services

1-800-252-0529

http://www.alcads.com

Airwaves Licensing

1-717-334-0910

http://www.airwaveslicensing.com

11. Technical Information

11.1. Device Addressing

Addressing Basics

One of the more powerful aspects of the *RV-M7 GX* transponder is its addressing scheme. Addressing allows multiple radio systems on the same frequency to co-exist, and not interfere with each other. Addressing is used to differentiate one *RV-M7* Transponder from another. Each unit has a unique number, so that when a position report is received, the *RV-M7 GX* that sent the message is known. It is not a security measure. Use the Security KEY to protect messages from being intercepted. Use the Addressing to identify individual *RV-M7 GX* transponders.

Firmware version B9 and higher includes a “Group Number” feature. If the group number is set to 0, this feature is ignored. If the Group Number is set to a number between 1-254, then the Group Number feature is automatically enabled, and all other radios in the system that wish to communicate with each other must have the same group number. If the group number of two modems do not match, they cannot communicate. The Group Number is set with the **ATGP xxx** command.

Each *RV-M7 GX* has a Unit Address programmed into it, and is represented as a 4 digit number. *RV-M7 Unit Address* address may be any number between 0001 and 9999. Every *RV-M7* has a Unit Address programmed into it, as well as the ID of the unit it will send data to. The Unit Address is programmed with the **ATMY xxxx** command, and the Unit Address of the destination modem (the Destination Address) is configured with the **ATDT xxxx** command.

Note: The underlying digital technology is a 16-bit address, and thus the valid address range is 0000 – FFFF in hex. Because the *RV-M7 GX* TDMA channel access method uses the decimal version of the ID to determine slot number, digits 0-9 are valid, but A-F should not be used.

This addressing scheme allows up to 9999 *RV-M7 GX* transponders to be on one radio channel, or split-up into sub-groups so they do not interfere with each other¹. For example, one group could use IDs 1200-1299 and another group use IDs 1300-1399. When properly configured, the two groups will not receive each other’s signals.

The default Unit Address in all *RV-M7 GX* modems is 0001, and 0001 is the default for the destination ID also. An Address Mask is used to select which digits of the address will be used to determine if a particular reception was intended for the *RV-M7* modem. The default Address Mask is F000, which means the *RV-M7 GX* will receive a transmission from any other *RV-M7* as long as the first digit matches, in this case, is a 0.

¹ Tech Note: The addresses are actually 0000-FFFF hex, allowing 64K addresses, but the TDMA transmission used in the M7 GX interprets them as decimal numbers, and ignores HEX characters.

When communicating over the air, *RV-M7* modems transmit their Group number, Unit Address and the Destination Address along with the data. Receiving modems check the received Group Number and Destination Address, and see if it matches their own Group and Unit Address. If it does match, the receiving modem outputs the data/position information it received via its serial port. If it does not match, the receiving modem discards the data, and does not send it out the serial port.

A way to disable addressing altogether, is set the Address Mask to 0000 (**ATMK 0000** command). This tells the *RV-M7* to ignore the address, and receive every transmission.

For a unit to receive a message from another unit, all of the following conditions must exist:

- *The two units must have the same group number (ATGP command)*
- *The bits in the TOID of the sending unit must match the bits in the MYID of the receiving unit that are designated in the address mask.*
- *If encryption is used, the KEYPHRASE of both units must match.*

Broadcast Transmissions

The double FF is used to identify a broadcast packet. A transmission with a two digit FF in the first two positions of the destination ID, or in the last two positions of the destination ID, will be interpreted as a broadcast, and any modem with an ID that matches the two non-FF digits will receive the data. For example, sending data with a destination ID of 12FF will be received by any modem with a unit ID 1200 through 12FF. Sending data with a destination ID of FF34 will be received by any modem with a unit ID of 0034 through FF34.

The Address Mask

Only in systems where some modems should only talk to certain other modems, might you want to change the address mask. Whenever data is received over the air, the Destination Address of the transmission is logically “ANDed” with the Address Mask in the receiving modem. This is the *Effective Destination Address*. The receiving *RV-M7* also ANDs its own Unit Address with its Address Mask. The result is the *Effective Unit Address*.

Addressing Examples:

Example 1 (default configuration)

Sending *RV-M7 GX* Unit Address = 0001

Sending *RV-M7 GX* Destination Address = 0001

Receiving *RV-M7 GX* Unit Address = 0001

Receiving Unit's Address Mask = F000

Result: Unit will receive the data, because the addresses identically match. When the addresses are identical, the value of the mask is not important.

Notes: This is the default configuration. All units have address 0001, and all modems will talk to all other modems with address 0001.

Example 2 (a configuration that won't work)

Sending to Destination Address = **1001**

Receiving Unit Address = **0001**

Receiving Unit's Address Mask = **F000**

Result: No data will be received, because the address do not match, and the address mask of FFFF requires that at least the first digit match. .

Example 3 (able to receive a data from a sub-group, 1000 – 1999)

Sending to Destination Address = **1236**

Receiving *RV-M7* Unit Address = **1234**

Receiving *RV-M7* Address Mask = **F000**

Result: Data will be received. 1236 ANDed with F00 is 1000. 1234 ANDed with F000 is 1000. The results of the ANDing perfectly match, and thus the data will be received.

Example 4 (able to receive from a sub-group, 34xx where xx is any two digits)

Sending Destination Address = **3410**

Receiving *RV-M7*'s Unit Address = **3499**

Receiving *RV-M7*'s Address Mask = **FF00**

Result: Data will be received. FF00 means first two digits must match, and they do, so the units will receive eachother.

11.2. Store-and-Forward Repeating

The *RV-M7 GX* transponder has a built-in wireless repeater/router. Each *RV-M7 GX* is capable of not only sending and receiving data from/to its serial port, but also re-transmitting over-the-air data. It is also able to re-transmit data that is addressed to other modems in the system.

To extend the communication range, program one or more *RV-M7 GX* transponders to be repeaters. Do not configure ALL to be repeaters, because they will typically just interfere with each other. It is best to locate one or two on elevated locations near the desired radio coverage area.

A store-and-forward repeater re-transmits a message as soon as it receives it. If one repeater is used on a system, they each message is sent on the air twice; once by the originating *RV-M7* and once by the repeater. This also means that each message takes twice as much air time if there is one repeater, 3X as much air-time with two repeaters...

Figure 1 Overview of Repeater Operation

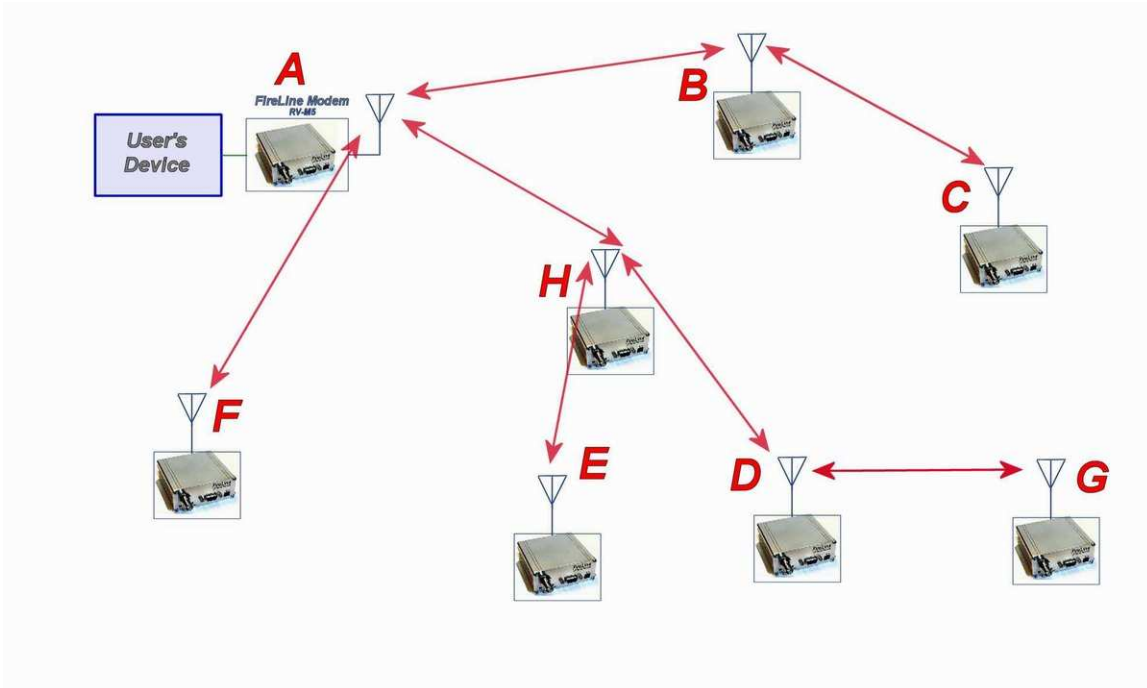

In the example shown in Figure 3 above, *RV-M7 A* will communicate with all other modems in the system. It can directly communicate with **B**, **H**, and **F**. Because of propagation limits, it cannot communicate reliably to **E**, **D**, **C**, and **G**.

To solve this problem, some of the *RV-M7* modems are configured as repeaters. They still are able to send and receive data, but they also will repeat data out to the modems that are out of range of *RV-M7 A*.

H is configured to repeat all messages to/from **E**, **D**, and **G**. **B** is configured to repeat all messages to/from **C**, and **D** is configured to repeat all messages to/from **G**.

Store-and-forward repeating is enabled with the **ATXR** command. **ATXR 1** enables repeating. **ATXR 0** disables it.

The *Repeat Source*, *Repeat Source Mask*, and the *Repeat Destination* are programmed into a Repeater Table in the *RV-M7*. The **ATX** command is used to program the Repeater Table. The Repeater Table may have up to 4 entries.

For example, *RV-M7 B* in the above example will have two entries in its Repeater Table. The command to set the two entries is:

```
ATX1 1020 FFFF 1000 FFFF  
ARX2 1000 FFFF 1000 FFFF
```

The first command above sets the Repeat Source to 1020 and the Repeat Destination to 1000, both with a Mask of FFFF. The FFFF mask means all digits of the source and destination are used to determine if the transmission should be repeated. All packets from units with MYID 1020 (**C**) sent to 1000 will be repeated

by this unit. It will not repeat messages from **D, E, F, G,** or **H** because their Unit IDs are not in the *Repeat Source* repeater table.

The second command above sets the Repeat Source to 1000 and the Repeat Destination to 1000, both with a Mask of FFFF. The FFFF mask means all digits of the source and destination are used to determine if the transmission should be repeated. All packets from units with MYID 1000 (**A**) sent 1000 will be repeated by this unit. In other words, all transmissions from **A** will be repeated by **B**.

To view the Repeater Table, use the **ATX** command, with no parameter. To view a single entry in the table, use the **ATXn**, where n=1, 2, 3, or 4.

A repeater will not repeat a transmission if it originated the transmission. If another M7 in the system has the same ID as the repeater, the repeater will not repeat data from that particular unit. The repeater's ID must be unique in the system.

To delete an entry in the table so it has no effect on the operation, set the fields to 0. For example, to disable make entry 1, use the **ATX1 0 0 0 0** command.

11.3. Setting the Over-The-Air Data Rate

The M7 has programmable over-the-air baud rates. The over-the-air rate is stored in register R2, and is programmed with the **ATR2 x** command, where **x** is a number corresponding to the rate. There are many possible baud rates, but not all rates may be used with all radio modem models. Consult the following table.

Over-the-air rate	Radio Bandwidth	Number of Modulation Levels	Position /Status Transmission Duration	RV-M7 Modem Models that support the rates
4800bps (R2=3) Default setting	12.5kHz or 25kHz	2	70mS	RV-M7-UC, RV-M7-UC-W
8000bps (R2=4)	12.5kHz or 25kHz	4	50mS	RV-M7-UC, RV-M7-UC-W
9600bps (R2=5)	25kHz	2	45mS	RV-M7-UC-W only
14400bps (R2=10)	25kHz	4	30mS	RV-M7-UC-W
5142bps (R2=7)	12.5kHz or 25kHz	2	65mS	RV-M7-UC-N, RV-M7-UC-W
9600bps (R2=8)	12.5kHz or 25kHz	4	45mS	RV-M7-UC-N, RV-M7-UC-W

Changing the over-the-air data rate will change the sensitivity of the receiver. Higher-data rates require a stronger signal at the receiver to be properly received, and thus have shorter range. The default over-the-air data rate for *RV-M7* radio modems is 4800 baud for narrow-band versions, and 9600 baud for wide-band versions.

The maximum over-the-air baud-rate for a narrow-band radio (12.5kHz channel-spacing) is 9600bps. Due to IF filter limitations, the *RV-M7* does not work as well at

9600 baud as at 4800 baud. Its performance is optimized for 4800 baud 2-level modulation and 8000 baud 4-level modulation.

If 4-level modulation is used (8000 and 9600 baud over-the-air), the “Modulation Balance” procedure must be re-done anytime the radio frequency is changed. This procedure must be done by a qualified radio technician. See section 11.7 for details on how to do this procedure.

The maximum over-the-air baud-rate for a wide-band model (25kHz channel spacing) is 19200bps. Due to IF filter limitations, it does not work as well at 19200 baud as lower data rates. Its performance is optimized for 9600 baud 2-level modulation.

11.4. TDMA Overview

TDMA, or *Time-Division-Multiple-Access* is a very effective way of allowing a lot of radios to share one radio channel. Used extensively in GSM cellular and APCO public-safety systems, TDMA excels at allowing quick and reliable access to radio channels. It allows 2-10 times more radios to share a radio channel than conventional carrier-sense methods. This allows 2-10 times more tracking radios on one channel, as compared to radios that do not have TDMA capability.

The following diagram illustrates how it works.

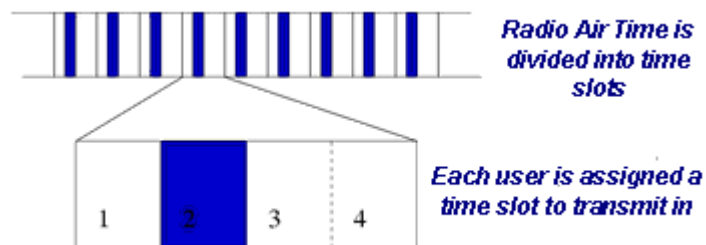

When a *RV-M7 GX* wants to report its position and status, it waits until its assigned time-slot, and then transmits its data. By default, TDMA time slot positions are assigned by unit-ID, so *RV-M7 GX* with ID 1 uses the first slot, and ID 2 uses the second slot, and so on.

A TDMA “*Frame*” time is the time it takes all units to transmit once. This is configured with the **TDMATIME xx** command. The factory default is 10 seconds, so every 10 seconds, each *RV-M7 GX* may transmit. The TDMA frame must be set long enough for all units to transmit. For example, if you have 50 *RV-M7s*, and use 200mS TDMA slots, then the **TDMATIME** should be set to 10 seconds. The simplest way to set it the **TDMATIME** is to make it equal to the **TXRATE**, the rate you wish to report position

The duration of a TDMA time slot is programmed into the *RV-M7 GX* with the **SLOTTIME** command. If **SLOTTIME** is set to 200 milliseconds (factory default), then every 10 seconds, the *RV-M7* will have a 200mS window to report its position in.

All TDMA frames are synchronized automatically in all *RV-M7 GX Transponders* to the top of the minute. Slot 0, frame 0 is at the top of each minute.

A unit may be allocated additional time slots. The SLOTQTY command sets the number of slots each unit receives. It is normally set to 1.

11.5. Configuring TDMA Operation

- Step 1.** Determine your over-the-air baud rate. See section 11.3 for information on baud-rate selection. Raveon recommends 4800 baud for narrow-band and 9600 baud for wide-band radios.
- Step 2.** Determine the position transmission time, in milliseconds. Again, review the table in section 11.3 to determine how long a position transmission at your selected baud rate will take.
- Step 3.** Repeaters. If a repeater will be used in the system, then the transmission time must be doubled, because each position will be transmitted twice, once by the originating RV-M7 and once by the repeater.
- Step 4.** Determine TDMA slot time required to send the position. Slot times are programmed with the **SLOTTIME** command, and are in 50mS increments. For example, if your position transmission requires 60mS, then the correct **SLOTTIME** to program would be 100mS. The **SLOTTIME** must be greater than the duration of the position transmission. If a repeater is used with a 60mS position report, then the **SLOTTIME** should be set to at least 150mS. Note, the SLOTTIME may be set longer than required to transmit a position, it just may not be shorter.
- Step 5.** Program the **TDMATIME**. The TDMA time must be greater than the maximum number of vehicles the system will ever need to support, times the SLOTTIME.
- $\frac{\text{\# of vehicles}}{\text{SLOTTIME}} \times \text{SLOTTIME} = \text{TDMATIME}$
- For example, if you will have up to 85 vehicles, and the SLOTTIME is 200mS, then the TDMATIME must be at least 17.4 seconds so a value of 20seconds for the TDMA time is appropriate.

11.6. Debug Related Commands

Bench Testing

(Must be in command mode to test. Enter +++ at the keyboard to put unit into config/test mode.)

- ATTD x** Various transmit test routines.
- 0 = Go back to normal mode. Stops the test.
 - 1 = Random data transmit.
 - 2 = Hop up/down one channel
 - 3 = Force PLL to fast lock mode
 - 4 = Transmit all 0s
 - 5 = Transmit all 1s
 - 6 = Enable the test points on the PCB.

7 = Transmit CW on center of channel
8 = Transmit preamble (101010 pattern)

- SHOW** Display an overview of the configuration.
- Ping xxxx** Ping another modem over the air. Transmits a request to xxxx to see if xxxx can hear the sending station. If it does, it answers with a response transmission, containing its ID and the signal strength of the reception. .
- ATST** Display statistics of how the modem is working.
- ATST 1** Display statistics of how the modem's GPS is working (-GX version only).
- AT\$5** Display RSSI. It will scroll the reading until another character comes in the serial port.

Packet Counter

The packet counter mode will output packet count statistics once per minute. It will output the number of packets received in the last minute as well as the running total. T

- ATPE** Begin counting and displaying the packet counters every minute
- ATPE 1** Reset the packet counters back to zero
- ATPE 2** Stop counting and displaying packet counters

Upon power up, the packet counter feature is always disabled.

11.7. Tune-up and Alignment

Do not key the transmitter for more than 30 seconds out of every 150 seconds if the RF power is set above 2 watts.

Radio calibration and alignment is performed using the **ATRx** commands. The *RV-M7* modem has been factory calibrated, in should not require any re-calibration when installed, or when changing frequency or channel. Unless the user is trained in radio test and calibration, the values stored in the R registers should not be modified.

Improper adjustment of the radio calibration (R0-R9 and RA registers), can result in failure of the radio modem.

Calibration and alignment values are stored internal to the modem in the "R" registers. (R0-R9 and RA). For example, to read R5, issue the **ATR8** command without any parameter. To change the setting, issue the **ATR8 nn** command, where nn is the new value you would like to store.

Once you read a register using an **ATRx** command, you may modify its value by entering a "U" for up or a "D" for down. U or D will change the value by one. Use this trick carefully, because it modifies the last R register that was read, and it is easy to unintentionally modify the wrong register.

Periodic Calibration

The only setting that may require adjustment is the center frequency. After years of operation, all crystals will age and change frequency slightly. The **ATR8**

command is used to adjust the center frequency. Like all narrow-band radios, semi-annual checks and adjustment of frequency is recommended.

Center Frequency

1. Key the transmitter with CW output using this command:
ATTD 7
2. The modem will now put out CW on the center of the channel.
3. Read the frequency offset with the **ATR8** command.
4. Adjust the frequency to the center of the channel with the **ATR8** command. You can use the “U” key and the “D” key to change the settings up and down one value in real time.

TX Deviation

1. Switch to channel 1.
2. Key the transmitter into a 50 ohm load using the **ATTD 3** command. The unit will now transmit, and send a digital 0 continuously. This should be +2.0kHz in frequency for narrow-band radios (12.5kHz spaced channels) and +4.0kHz for wide-band (25kHz channels).
3. Adjust the deviation register setting so that the frequency deviation is correct. The deviation is set with a digital adjustment. Use the **ATRO** command to read or set the deviation level.

TX Modulation Balance

This procedure must be done anytime 4-level modulation is used and the RF channel frequency is changed.

1. Set-up a service monitor to monitor the FM deviation of the transmitted signal on an oscilloscope. The frequency response of the demodulated FM signal must be greater than 10Hz to 5kHz without any de-emphasis.
2. Transmit random data with the *RV-M7*, using the **ATDT 1** command. This command will cause the *RV-M7* to automatically key up, and send random data for one minute.
3. Verify the DC center of the demodulated data is stable. The random data should be randomly timed 1s and 0s, and have little to no AC component on them. See pictures below for details.
4. If necessary, change the **ATR9** setting so that the long data bit have the same amplitude and DC value as the shorter ones and that the transmit “eye” pattern is as wide as possible.

11.8. RS232 Serial Port Options

Flow Control

If large amounts of data will be sent with the *RV-M7*, it may be possible to overflow the internal data buffer. To ensure the transmit buffer does not overflow, enable

and use hardware flow control. Hardware flow control is enabled with the **ATCH 1** command. Note that the *RV-M7* modem will always indicate the status of its internal buffer using the **CTS** signal on the DB-9 serial connector. When CTS is negated, the internal buffers are more than 80% full. When it is asserted and it is “Clear to Send”, the buffers are less than 80% full.

RX Carrier Detect

The DCD signal from the modem may be generated by detection of RF, using an internal signal called RSSI (Receive Signal Strength Indication). The RSSI signal is an analog signal representing the strength of the RF carrier. It is compared with a pre-set value, and if it is above this value, Carrier Detect is asserted. The pre-set value may be change with the **ATRA** command.

When the modem is used in the Streaming Mode (non-packetized operation, you may wish to configure the modem to require RF carrier detect to be active for the modem to receive data. Use the **ATRF** command to enable/disable this feature.

To set the RF carrier detect level, perform the following steps:

1. Generate a test signal, 1kHz tone, 1.5kHz deviation, on the receive frequency. Connect the signal generator to the antenna input. Turn the RF level off.
2. Watch the RSSI DAC value by issuing the **AT\$5** command. The current reading will be sent out the serial port.
3. Adjust the RF level to a point where you would like the RSSI to trigger the CD signal. This is factory-set to -110dBm.
4. Send the **ATRA nnn** command. Set **nnn** to be equal to the RSSI setting you would like the CD signal to trip at. The BUSY LED will also indicate an RF carrier when the RF carrier is above the threshold set with the **ATRA** command.
5. Generate an RF signal on-channel with a level of -110dBm. Verify the Power/BUSY LED stays on. If it does not, repeat step 4, adjusting in increments of 10.

Busy-Channel Lock Out

If your system operation require the *RV-M7* modem to monitor-before-transmit, of if you do not want the *RV-M7* to transmit on a channel that is busy, you can enable “Busy-Channel-Lockout”, using the **ATBC 1** command. **ATBC 0** disables BCL, and thus the modem will transmit whenever it has data to send out.

12. RV-M7 Diagnostic Provisions

12.1. Overview of Diagnostics

Internal to the *RV-M7* radio modem, is a powerful 32-bit microprocessor. Along with handling all aspects of radio modulation and demodulation, the microprocessor also maintains an extensive array of diagnostic information.

This section details the diagnostic information available, and describes how to use the information to optimize or troubleshoot a *RV-M7* radio network.

12.2. Reading the Diagnostic Information

RV-M7 diagnostic information is read using AT commands, while the unit is in the Command Mode. Refer to the section “User Serial Port Commands” to learn how to put the *RV-M7* modem into the Command Mode.

To see a general overview of how the modem has been operating, use the **ATST** command (status request command), without any parameter. The radio modem will respond with a list of certain operation statistics that it maintains. All statistics start counting at 0. The ATST 1 command can be used to reset all statistics back to 0, except the run-time timers.

Other operation and configuration statistics are available using the ATST command, with a parameter to specify the desired statistic. The following table describes the various statistics available.

12.3. Status and Statistics Command

AT Command	Command Description	Response
ST	General Communication Statistics – This command will cause the <i>RV-M7</i> to output a table of various operational statistics.	Statistics overview screen
ST1	GPS Statistics – Statistics related to the GPS operation, if installed.	GPS Statistics overview screen
ST2	Low-level internal statistics – Returns various low-level statistics. These are subject to change in various firmware revisions.	Low-level statistics screen
ST3	Compile date and time – Returns the data and the time that the firmware was compiled.	Date and time
ST4	Run Time – Returns the amount of time that the modem has been powered up and running.	Run time display screen
ST9	Reset all statistics counters	OK

ST10

Statistic Read – Returns numeric values, comma separated, of all statistics as described in the ST command.

Run time display
screen

12.4. ATST Command

The ATST command, will return the following information:

```
STATISTICS
Good RX Packets : nnn (packets received over the air with no bit-errors and correct address)
With Bad CRCs   : nnn (over-the-air packets with bit errors that were discarded)
With Bad Noise  : nnn (receptions that were aborted due to noise, CW jamming, lost signal...)
Bytes received  : nnn (number of bytes this modem received, and sent out its serial port)
Bytes transmitted: nnn (number of bytes this modem received via the serial port, and transmitted
over the air)

Packets send    : nnn (number of packets this modem has transmitted over the air.
Retransmissions in the ARQ mode are not counted)

ACKs received   : nnn (Number of ACK packets this modem received, when ARQ was enabled)
ACKs transmitted: nnn (Number of ACK packets sent over-the-air in the ARQ mode)
Pkts last minute: nnn (Number of packets received during the last minute)
UART errors     : nnn (serial port framing and overrun errors. Usually these are caused by
incorrect serial port settings)

OK
```

If there is a hardware problem, there may be one or more hardware error messages listing the error types (CPU Exceptions, OS Rebooted, or Fatal OS failures). Consult the factory if any of these messages ever appear.)

12.5. ATST1 Command (GPS Statistics)

The ATST 1 command, will return various information regarding the operation of the GPS features in the RV-M7 GX.

12.6. ATST2 Command

The ATST2 command, will return additional lower-level statistics:

```
RF FIFO overruns : nnn (number of times the modem was too busy to receive data over-the-air)
Wrong address    : nnn (packets with addresses intended for some other unit. Also will count
apparent false packets due to random noise)

Duplicate packets: nnn (number of packets discarded because they already were received, and
subsequently re-received due to ARQ mode or a repeater)

Missing ACKs     : nnn (number of transmissions in ARQ mode, where this sending RV-M7 did not
receive an ACK back as it expected to)

TX FIFO overflows: nnn (number of bytes of data that came into the RV-M7 over-the-air, and there
because there was no buffer space for the data, were discarded. If greater
than 0, the serial-port baud-rate should be increased. )

RX FIFO overflows: nnn (number of bytes of data came into the RV-M7's serial port, and there was
no room in the RV-M7 to buffer the data before transmission, so these
bytes were discarded. If greater than 0, flow-control should be enabled,
hardware flow-control implemented, or the serial-port baud rate reduced.)

OS loop time    : nnn (number of times OS executes, per baud. Typical 10-200. 0 or >5000
means there is a serious OS problem).

OS Speed        : nnn (speed of the main Operating System, in Hz. Typical 8000-30000. )
VCO Bias        : nnn (the DAC value that biases the VCO in the radio. 0-1024 = 0-3.3V)
Config          : hhhh (hexadecimal representation of an internal configuration word.)

OK
```

12.7. ATST3 Command

The ATST3 command, will return the time and date the firmware in the *RV-M7* was compiled.

12.8. ATST4 Command

The ATST4 command will return internal timers that tell how long the modem has been powered up and running. All of these timers restart a 0 upon power up.

```
Run time:
Years: nnn (number of years running)
Days : nnn (number of days running, resets to 0 after one year)
Hours: nnn (number of hours running, resets to 0 after 23 hours, 59 minutes, 59 seconds)
Min:   nnn (number of minutes running, resets to 0 after 59 minutes, 59 seconds)
Sec:   nnn (number of seconds running, resets to 0 after 59 seconds)
Uptime: nnn (number of seconds running. Does not reset.)
OK
```

13. Antenna Information

Key to a successful installation is the choice and installation of a good antenna system. A good quality antenna can more than double the range of a radio system. Properly locating the antenna is vital to creating a quality radio link, and a poor installation can decrease the range of the system by as much as 90%.

Use these guidelines to evaluate your antenna system design, and be sure contact a quality radio communication equipment distributor such as *Talley Electronics* (<http://www.talleycom.com>) to help choose the proper antenna for your system.

To increase your communications range, locate the antenna high as needed, practical, safe, and allowed by your license. On fixed base-station applications, you may utilize an antenna with gain. *Note: The maximum Permissible Exposure (MPE) for this product was computed using a 0dB gain antenna, and must be recalculated if a gain antenna is used.*

Height

Try to locate the antenna as high above obstructions, vehicle, and buildings as possible. UHF radio channels require a clear “line-of-sight” between the transmitter and the receiver. Radio waves will penetrate buildings, and reflect off and around obstacles, but the fewer obstacles between stations the better the signal quality.

Gain

Antennas are specified by their gain. They actually do not have gain, but rather they can increase the strength of a signal in certain directions, at the expense of attenuating signals from other directions. Gain antennas always have “patterns” of gain. It is important you understand the pattern of your antenna. Omni directional antennas will receive from almost any angle, 360 degrees around them.



Omni Antenna

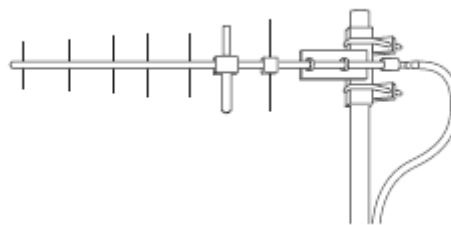

Directional Antenna

14. Troubleshooting

Symptom: Unit will not receive

Solution #1. Verify that the modem is on the correct RF channel. If it is, the Status LED should blink green every time another modem tries to transmit to it. If the Status LED does not blink when it should be receiving, it is on the wrong RF frequency.

Solution #2. If the addresses match, and Status LED blinks green but still no reception of data, verify that the RTS signal is asserted. The *RV-M7* will not output data if the RTS signal on the DB-9 I/O connector is not asserted. If the user's hardware cannot assert the RTS hardware line, disable hardware flow control in the *RV-M7* modem, using the **ATCH 0** command.

Solution #3. If the Status LED blinks green, verify that the Unit Address of the sending modem matches the unit address of the receiving modem. If this is OK, verify that the over-the-air baud rate of all modems is the same (ATR2 command).

Solution #4. Verify Low Power Mode. The *RV-M7* has an optional Low Power Mode (LPM). If LPM is enabled, the *RV-M7* will power down whenever the DTR line of the serial port is turned off. The Power LED will blink once every 10 seconds in the LPM mode. The **ATSM** command is used to set or read the Low Power Mode. **ATSM 1** enables it, and **ATSM 0** disables it. If LPM is used (**ATSM 1**), then the *RV-M7* will turn off when the DTR line is off, or the program connected to the serial port is closed, or the RS-232 connector is unplugged.

Solution #5. Verify the KEYPHRASE is correct. If encryption is used, the KEYPHRASE is set to a unique word, and must be the same in all radios in the system. If it is not used in the radio system, then the KEYPHRASE in all units must be disabled or left at the factory default. To disable encryption, use the KEYPHRASE 0 command. The factory default KEYPHRASE is RAVEON, in all capital letters.

Symptom: Unit will not transmit

Solution #1. Verify that CTS is wired. Some devices that could be connected to the *RV-M7* will require the CTS signal to be asserted. The *RV-M7* does assert this signal, but if the wire is not connected, your device may not be outputting data to the *RV-M7*. If the TX LED blinks, the *RV-M7* is transmitting data. Every time data enters the modem, the TX LED should blink.

Solution #2. Verify that serial port timeout is OK. The ATG0 command sets the number of milliseconds that the *RV-M7* will look for in the serial input data stream. If a pause greater than this value happens, the modem will transmit. If the ATG0 parameter is set very large, say 20000, this means 2 seconds, and the modem may simply be waiting a long time.

Solution #3. Verify that the radio channel is clear or BCL is off. The **ATBC 1** command enables Busy Channel Lockout. If BCL is on, the modem will not transmit on a busy channel. The **ATBC 0** command turns it off, and thus the modem will transmit when it needs to, regardless if the channel is busy. The Status LED on the front of the modem is illuminated green whenever the radio channel is busy (RF present).

Solution #4. Verify Low Power Mode. The *RV-M7* has an optional Low Power Mode (LPM). If LPM is enabled, the *RV-M7* will power down whenever the DTR line of the serial port is turned off. The Power LED will blink once every 10 seconds in the LPM mode. The **ATSM** command is used to set or read the Low Power Mode. **ATSM 1** enables it, and **ATSM 0** disables it. If LPM is used (**ATSM 1**), then the *RV-M7* will turn off when the DTR line is off, or the program connected to the serial port is closed, or the RS-232 connector is unplugged.

Solution #5. Verify trigger input bit 3 is not enabled. The *RV-M7 GX* has the ability to use the TxD input pin of the RS232 port as a general-purpose digital input. If this bit is used as an input, the *RV-M7 GX* modem will not transmit serial data entering the serial port. IN3 is the serial data input.

Use the **TRIGBITS xx** command to set which bits to use for inputs, and **TRIGBITS 0** to disable all input bits. This hint only applies to the –GX version of the RV-M7 radio modem.

Symptom: Receive light blinks, but no data is received

Solution #1. Verify Input/Output Configuration. The RV-M7 GX has numerous I/O options. RS232 is standard, but RS485 or RS422 may be configured also. Use the ATIO command to view how the I/O is configured. ATIO 0 is the default (RS232 mode).

Solution #2. Verify the serial port baud rate. This is difficult if it is set wrong, because you cannot enter the command mode to check it. Try all possible baud rates, and see if one of them works with the modem. Alternately, remove the rear cover of the modem, and press the CONFIG button. This will force the modem into the Command Mode, as well as set the serial port to 9600 baud, 8 data bits, one stop, and no parity. If the baud-rate was OK, verify the AT, BT and CT times, that they are long enough for you to enter the +++ string.

Solution #3 Verify the KEYPHRASE is correct. If encryption is used, the KEYPHRASE is set to a unique word, and must be the same in all radios in the system. If it is not used in the radio system, then the KEYPHRASE in all units must be disabled or left at the factory default. To disable encryption, use the KEYPHRASE 0 command. The factory default KEYPHRASE is RAVEON, in all capital letters.

Symptom: Long delay before transmitting

Solution #1. Verify that serial port timeout is OK. The ATR3 command sets the number of milliseconds that the RV-M7 will look for in the serial input data stream. If a pause greater than this value happens, the modem will transmit. If the ATG0 parameter is set very large, say 2000, this means 2 seconds, and the modem may simply be waiting a long time. Typical settings for this parameter are 20 (20mS).

Symptom: Cannot enter Command Mode

Solution #1. Verify the serial port baud rate. This is difficult if it is set wrong, because you cannot enter the command mode to check it. Try all possible baud rates, and see if one of them works with the modem. Alternately, remove the rear cover of the modem, and press the CONFIG button. This will force the modem into the Command Mode, as well as set the serial port to 9600 baud, 8 data bits, one stop, and no parity. If the baud-rate was OK, verify the AT, BT and CT times, that they are long enough for you to enter the +++ string.

Solution #2. Handshaking. You may have hardware handshaking enabled on your terminal program, but the hardware or cable may not support it. Disable hardware handshaking on your terminal program to verify this is the issue.

Symptom: Modem appears dead.

Solution #1. Verify the power is on. When the modem has good DC power, the PWR LED will blink once every two seconds. If it is not blinking, either the modem does not have power, the modem is broken, or the LEDs have been disabled via the **ATL0** command.

Solution #2. Verify the internal fuse OK. There is an internal fuse in the RV-M7, protecting it from reverse-voltage and electrical failures. If the power LED does not blink or come on when DC is applied, check the fuse and replace it with the same type 3-amp mini fuse, and try again. If you replace the fuse, the unit must be carefully check for damage and proper operation before being installed. If you replace the fuse, you must use a *Littlefuse* brand fuse, part number 0297003 or Raveon part, number 1X726-3 to maintain calibration of your unit.

Solution #3. Verify Low Power Mode. The RV-M7 has an optional Low Power Mode (LPM). If LPM is enabled, the RV-M7 will power down whenever the DTR line of the serial port is turned off. The Power LED will blink once every 10 seconds in the LPM mode. The **ATSM** command is used to set or read the Low Power Mode. **ATSM 1** enables it, and **ATSM 0** disables it. If LPM is used (**ATSM 1**), then the RV-M7 will turn off when the DTR line is off, or the program connected to the serial port is closed, or the RS-232 connector is unplugged.

Symptom: Repeater will not repeat.

Solution #1. Verify the repeater's Unit ID is unique. An RV-M7 configured to be a repeater will not repeat messages it originated. If other units in the system have the same ID as the repeater, the repeater will not repeat them because it thinks that it originated the transmission. Set the MYID of the repeater to a unique ID number.

Solution #2 Verify the KEYPHRASE is correct. If encryption is used, the KEYPHRASE is set to a unique word, and must be the same in all radios in the system. If it is not used in the radio system, then the KEYPHRASE in all units must be disabled or left at the factory default. To disable encryption, use the KEYPHRASE 0 command. The factory default KEYPHRASE is RAVEON, in all capital letters.

Symptom: Transmits position, but no data.

Solution #1. Verify DATAMUTE is not enabled. DATAMUTE disables data transmission. It must be set to 0 for serial port data transmission or WMX transmit data.

Solution #2. Verify SLOTTIME is long enough. The TDMA slot time must be long enough for data to be transmitted in. Adjust the system slot time (SLOTTIME), or give the particular unit an extra slot using the SLOTQTY command.

15. Mechanical

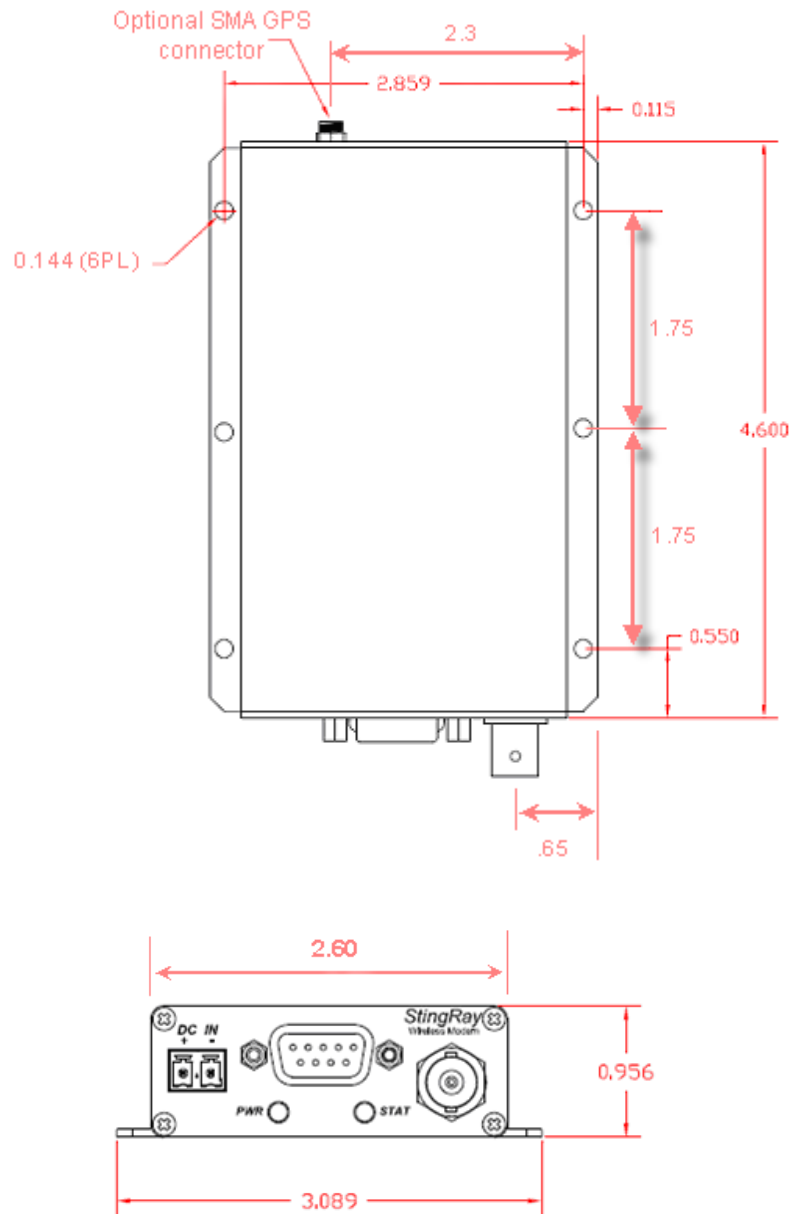

16. RV-M7 GX Messages

The *RV-M7 GX* sends and receives messages in the NMEA 0183 format. NMEA is a standard protocol, use by GPS receivers to transmit data. NMEA output is EIA-422A but for most purposes it is RS-232 compatible. Use 4800 bps, 8 data bits, no parity and one stop bit (8N1) for standard NMEA data.

NMEA 0183 sentences are all ASCII characters. Each sentence begins with a dollar sign (\$) and ends with a carriage return linefeed (<CR><LF>). Data is comma delimited. All commas must be included as they act as markers. Some GPS do not send some of the fields. A checksum is added to the end of the message. Following the \$ is the address field aacc. aa is the device id. "GP" is used to identify GPS data. Transmission of the device ID is usually optional. ccc is the sentence formatter, otherwise known as the sentence name.

The *RV-M7 GX* supports the NMEA standard WPL, TLL, GGA, and GSV sentences. The Raveon proprietary PRAVE sentence is sent out of the *RV-M7 GX* in GPS mode 2. It is used by PC software programs to track *RV-M7 GX* transponders, and process their status information.

16.1. \$GPTLL Target Lat-Lon

This sentence is typically used by marine radar plotters. When the *RV-M7 GX* is set to **GPS 3** mode of operation, it will output this message every time it receives a position report from another *RV-M7 GX* transponder. Within the TLL message, is the latitude, longitude, and Target ID". In the Target ID field, the *RV-M7 GX* puts the ID of the RV-M7 that transmitted its position.

`$GPTLL,1,2,3,4,5,6,7,8,9 * cks`

Field	Usage	Comments
	\$ GPTLL	TLL header
1	Target number	01-99. Note the 99 target limit of most systems. If the ID is greater than 99, the <i>RV-M7 GX</i> will only output 2 digits.
2	Lat	Latitude of the point.
3	N/S	North or South. One character.
4	Lon	Longitude of the position
5	E/W	East or west. One character.
6	Target Name	The ID of the unit that transmitted its position. If a Prefix" is programmed into the RV-M7, the name will have the prefix characters in front of the ID. If additional parameters were selected to be appended, these will be put at the end of the name. See the "TLLPARAM" command for a list of possible parameters. All parameters are enclosed in one set of parenthesis after the ID number.
7	UTC time	The UTC time at the time the transmission was made. Hhmmss format.
8	Status	The character T, for tracking.
9	Reference	Null field. No data
cks		NMEA checksum

Example:

The following sentence is from unit 0006, prefix set to “BUOY”, temperature and voltage parameters appended.

```
$GPTLL,06,3308.9098,N,11713.1306,W,BUOY6(27C 12.9V ),41840,T,*06
```

16.2. \$GPGSV Satellites In View

When this message comes out of the *RV-M7 GX*, it identifies the number of satellites its internal GPS has in view. Up to 3 satellites may be reported in one message. The *RV-M7 GX* typically does not report any satellite information other than the Number of Satellites in view.

```
$GPGSV,1,2,3,4,5,6,7 * cks
```

<u>Field</u>	<u>Usage</u>	<u>Comments</u>
	\$ GPGSV	Number of SVs in view, PRN numbers, elevation, azimuth & SNR values.
1	Count	Total number of messages of this type in this cycle
2	Message number	This message's number
3	Number of sats	The total number of satellites in view.
4	PRN	Satellite number.
5	Elevation	Elevation in degrees, 90 maximum
6	Azmuth	Azimuth, degrees from true north, 000 to 359
7	SNR	Signal-to-noise ratio for this sat.
cks		NMEA checksum

16.3. \$GPWPL Waypoint Location

The waypoint location sentence is used by GPS receivers and plotters in different ways, often to share waypoint data or to show waypoints on-screen.

```
$GPWPL,1,2,3,4,5,6 * cks
```

<u>Field</u>	<u>Usage</u>	<u>Comments</u>
	\$ GPWPL	Waypoint Location Message Header
1	Lat	Latitude of the point.
2	N/S	North or South. One character.
3	Lon	Longitude of the position
4	E/W	East or west. One character.
5	WP Name	The ID of the unit that transmitted its position plus any user-set prefix.
cks		NMEA checksum

When the *RV-M7 GX* is set to **GPS 4** mode of operation, it will output this message every time it receives a position report from another *RV-M7 GX* transponder. Within the WPL message, is the latitude, longitude, and “waypoint ID”. In the

waypoint ID field, the *RV-M7 GX* puts the ID of the RV-M7 that transmitted its position.

For example, if a *RV-M7 GX* receives a position report from ID 0003 located at 4917.16N , 12310.64W it sends out the following message.

```
$GPWPL,4917.16,N,12310.64,W,3*65
```

The lat/lon is sent using the dddmm.mm format, where ddd is the degrees, and mm.mmmmm is the decimal minutes. There is no sign to these numbers.

GPS 4 mode with the \$GPWPL message is the most common way of using the *RV-M7 GX* with a hand-held or mobile GPS. Most any GPS with a serial-data input will accept the \$GPWPL message, and put an icon on its screen, with a label showing the ID of the RV-M7 at that position.

Some GPS display have an issue when a new position report is received. Most will move the waypoint to the new location, but some re-draw a new waypoint at the new position, and leave the old waypoint in place.

To help make the waypoints easier to read, the *RV-M7 GX* may be programmed with an ID prefix, using the **PREFIX vvvv** command. The default is a capitol letter V. Set it to a dash “-“ to disable the prefix string. If a prefix is programmed into the RV-M7, it will add the prefix characters whenever it outputs the ID in a \$GPWPL message. For example, if the prefix is set to the phrase “Car”, the *RV-M7 GX* will output the following message when it receives a position report from RV-M7 Transponder with ID 0003.

```
$GPWPL,4917.16,N,12310.64,W,Car3*65
```

And on a GPS display connected to the RV-M7, the waypoint will show up at the correct lat/lon with the waypoint name “Car3”. In most all GPS receivers, this waypoint will also be added to its internal database of waypoints.

16.4. \$PRAVE Raveon Proprietary Message, Location-Status

The \$PRAVE message is sent out the *RV-M7 GX* when it is configured for **GPS 2** mode of operation. This mode is typically used with the RavTrack PC program, or other computer programs that can process position and status information. It is sent at 38.4K bytes/second out the serial port.

Along with ID and position information, it contains a host of other status information. The length of this message may exceed the standard NMEA limit of 79 characters. Any product or software that uses this message must take this into account.

Following is a list of the fields sent in this message

Field	Usage	Comments
1	\$PRAVE	Raveon Proprietary Header
2	From ID	The ID of the transponder that transmitted its position over the air. It is a decimal number, 0 – 9999.
3	To ID	The ID that this position report was sent to. It is a decimal number, 0 – 9999.

4	Latitude	dddmm.mmmm format. It is signed. + is north, - is south. No sign means north. Note: typically there are 4 decimal places, but as few as 0 decimal places are possible. Null field if no GPS lock.
5	Longitude	dddmm.mmmm format. It is signed. + is east, - is west. No sign means east. Note: typically there are 4 decimal places, but as few as 0 decimal places are possible. Null field if no GPS lock.
6	UTC time	The UTC time at the time the transmission was made. Hhmmss format. Null field if no GPS lock.
7	GPS Status	0=not valid position. 1=GPS locked and valid position. 2=Differential or WAAS fix.
8	Num Satellites	The number of satellites in view
9	Altitude	The altitude in meters. Null field if no GPS lock.
10	Temperature	The internal temperature of the RV-M7 in degrees C. Typically this is 5-20 degrees above ambient.
11	Voltage	Input voltage to the device that sent this position.
12	IO status	A decimal number representing the binary inputs.
13	RSSI	The signal-strength of this message as measured by the receiver, in dBm. Note, if the message went through a repeater, it is the signal level of the repeated message.
14	Speed	The speed of the device in km/hour, 0-255
15	Heading	The heading of the device 0-360 degrees
16	Status	Status flags received from the device. Not all products support generating all status flag codes. NULL means no alerts. "P" means a proximity alert. "M" means man-down alert "A" General alert, usually due to pressing an alert button "C" Critical alert, usually due to pressing and holding alert button "I" Impact alert "V" Vibration "S" Service required on product
17	Spare	A spare field. May be used for UTC date in the future. Typically NULL.
18	*	The "*" NMEA end-of-message identifier.
19	Checksum	The NMEA 0183 checksum.

Example Sentence:

\$PRAVE,0001,0001,3308.9051,-11713.1164,195348,1,10,168,31,13.3,3,-83,0,0,*,*66

This example shows a unit at 33° 8.9051 north latitude and 117° 13.1164 east longitude. It is not moving (0 speed). Its signal strength was -83dBm. Its altitude is 168 meters.

\$GPGLL,3308.7292,N,11713.7886,W,155803,A,*1C
\$GPVTG,0,T,,0.00,N,0.00,K,*1F
\$GPGLL,3308.7284,N,11713.7882,W,155813,A,*1E
\$GPVTG,0,T,,0.00,N,0.00,K,*1F
\$GPGLL,3308.7273,N,11713.7880,W,155823,A,*17
\$GPVTG,28,T,,1.08,N,2.00,K,*2E
\$GPGLL,3308.7226,N,11713.7896,W,155833,A,*11
\$GPVTG,140,T,,1.62,N,3.00,K,*1C
\$GPGLL,3308.7140,N,11713.7860,W,155843,A,*1C
\$GPVTG,260,T,,1.62,N,3.00,K,*1D
\$GPGLL,3308.7134,N,11713.7998,W,155853,A,*18
\$GPVTG,266,T,,3.24,N,6.00,K,*1E
\$GPGLL,3308.7145,N,11713.8037,W,155903,A,*19
\$GPVTG,74,T,,3.78,N,7.00,K,*27
\$GPGLL,3308.7182,N,11713.7927,W,155913,A,*14
\$GPVTG,56,T,,2.70,N,5.00,K,*2C
\$GPGLL,3308.7224,N,11713.7891,W,155923,A,*14
\$GPVTG,56,T,,1.08,N,2.00,K,*27
\$GPGLL,3308.7233,N,11713.7899,W,155933,A,*1B
\$GPVTG,0,T,,0.00,N,0.00,K,*1F
\$GPGLL,3308.7219,N,11713.7902,W,155943,A,*17
\$GPVTG,0,T,,0.00,N,0.00,K,*1F

Limited One Year Warranty

If within one year from date of purchase, this product fails due to a defect in material or workmanship, Raveon Technologies, Incorporated will repair or replace it, at Raveon's sole discretion. This warranty is extended to the original consumer purchaser only and is not transferable.

This warranty does not apply to: (a) product damage caused by accident, dropping or abuse in handling, acts of God or any negligent use; (b) units which have been subject to unauthorized repair, opened, taken apart or otherwise modified; (c) units not used in accordance with instructions; (d) damages exceeding the cost of the product; (e) batteries; (f) the finish on any portion of the product, such as surface and/or weathering, as this is considered normal wear and tear; (g) transit damage, initial installation costs, removal costs, or reinstallation costs; (h) damage due to lighting, floods, fire, or earthquakes.

RAVEON TECHNOLOGIES INCORPORATED WILL NOT BE LIABLE FOR INCIDENTAL OR CONSEQUENTIAL DAMAGES. SOME STATES DO NOT ALLOW THE EXCLUSION OR LIMITATION OF INCIDENTAL OR CONSEQUENTIAL DAMAGES, SO THE ABOVE LIMITATION OR EXCLUSION MAY NOT APPLY TO YOU. THIS WARRANTY IS IN LIEU OF ALL OTHER EXPRESS OR IMPLIED WARRANTIES. ALL IMPLIED WARRANTIES, INCLUDING THE WARRANTY OF MERCHANTABILITY AND THE WARRANTY OF FITNESS FOR A PARTICULAR PURPOSE, ARE HEREBY MODIFIED TO EXIST ONLY AS CONTAINED IN THIS LIMITED WARRANTY, AND SHALL BE OF THE SAME DURATION AS THE WARRANTY PERIOD STATED ABOVE. SOME STATES DO NOT ALLOW LIMITATIONS ON THE DURATION OF AN IMPLIED WARRANTY, SO THE ABOVE LIMITATION MAY NOT APPLY TO YOU.

This warranty gives you specific legal rights and you may also have other rights which vary from state to state.

Warranty service is available by mailing postage prepaid to:

*Raveon Technologies Corporation
990 Park Center Drive
Suite C
Vista, CA 92081*

To obtain warranty service, include a copy of the original sales receipt or invoice showing the date, location, and price of purchase. Include a written description of the problem with the product, a phone number and name of person who may be contacted regarding the problem, and the address to where the product should be returned.

Products repaired under warranty will typically have their program memories erased and reset to factory default settings.